

400 SERIES WINDOWS WITH TRIPLE-PANE GLASS

SPECIFICATION GUIDE FOR PROFESSIONALS

CONTENTS

Casement & Awning Windows	
Table of Sizes	1-5
Specifications	6-10
Custom Sizes	11-12
Grilles	13
Window Details	14-17
Joining Details	18
Tilt-Wash Windows	
Table of Sizes	19-23
Specifications	24-30
Custom Sizes	31
Grilles	32
Window Details	33
Joining Details	34
Specialty Windows	
Table of Sizes	35-37
Specifications & Grilles	38
Window & Joining Details	39
Complementary Specialty Windows	
Shapes & Sizes	40
Window & Joining Details	41
Combination Designs	42-48
Product Performance	49-56

For warranty information, visit andersenwindows.com/warranty.

Visit andersenwindows.com/triplepane for more information on triple-pane windows and patio doors.

Go to andersenwindows.com/400series for 400 Series window features, options and accessories; or see the 400 Series Product Guide for Professionals which can also be found on andersenwindows.com.

400 SERIES WINDOWS WITH TRIPLE-PANE GLASS



Table of Sizes for Casement and Transom Windows With Triple-Pane Glass (continued)

Scale 1/8" (3) = 1'-0" (305) – 1:96

Window Dimension	5'-2 3/4" (1594)	5'-11 5/8" (1819)	5'-1" (1549)	5'-11 7/8" (1826)	7'-0 5/8" (2149)
Minimum Rough Opening	5'-3 1/4" (1607)	6'-0 1/8" (1832)	5'-1 1/2" (1562)	6'-0 3/8" (1838)	7'-1 1/8" (2162)
Unobstructed Glass (casement, single sash only)	27 1/8" (689)	31 9/16" (802)	16 1/8" (410)	19 3/4" (502)	24" (610)
Unobstructed Glass (single transom)	57 15/16" (1472)	66 13/16" (1697)	56 3/16" (1427)	67 1/16" (1703)	79 13/16" (2027)
CUSTOM WIDTHS – 17" to 84 5/8"					
1'-0" (305)					
1'-0 1/2" (318)					
2'-0 1/8" (613)					
2'-0 5/8" (625)					
2'-0 7/8" (733)					
2'-4 3/8" (721)					
2'-4 7/8" (733)					
2'-11 15/16" (913)					
3'-0 1/2" (927)					
3'-1 5/8" (927)					
3'-4 13/16" (1037)					
3'-5 3/8" (1051)					
4'-0" (1219)					
4'-0 1/2" (1232)					
4'-4 13/16" (1341)					
4'-5 3/8" (1356)					
4'-11 7/8" (1521)					
5'-0 3/8" (1534)					
5'-1 1/8" (1549)					



Custom-size windows are available in 1/8" (3) increments. Windows can also be custom sized to match standard sizes ending in a 1/16" (1.5) of an inch. See pages 11-12.

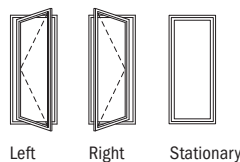

Choose left, right or stationary as viewed from the exterior. In addition to venting shown in table, other standard configurations are available for single, twin and triple windows. Transom (CTR) windows are stationary only. **Transom (CTR) windows can be used over casement or awning windows, and may be rotated 90° and used as a sidelight with casement, awning or picture windows.** Available with either traditional or contemporary trim stops. Grille information shown on page 13. Details shown on pages 14-18.

* Window Dimension always refers to outside frame-to-frame dimension.
 • Minimum Rough Opening dimensions may need to be increased to allow for use of building wraps, flashing, sill panning, brackets, fasteners or other items.
 • Dimensions in parentheses are in millimeters.
 ◊ Meets or exceeds clear opening area of 5.7 sq. ft. or 0.53 m², clear opening width of 20" (508) and clear opening height of 24" (610) with appropriate hinge specified.
 * Available with straight-arm operator (hinged for widest clear opening) which meets clear opening width of 22" (559).

Casement & Awning Windows

400 SERIES WINDOWS WITH TRIPLE-PANE GLASS



Table of Sizes for Awning Windows With Triple-Pane Glass

Notes on the next page also apply to this page.

Scale 1/8" (3) = 1'-0" (305) – 1:96

Window Dimension	2'-0 1/8"	2'-4 3/8"	2'-7 1/2"	2'-11 15/16"	3'-4 13/16"	4'-0"	4'-4 13/16"	4'-11 7/8"	5'-4 13/16"	5'-11 7/8"
	(613)	(721)	(800)	(913)	(1037)	(1219)	(1341)	(1521)	(1646)	(1819)
Minimum Rough Opening	2'-0 5/8"	2'-4 7/8"	2'-8"	3'-0 1/2"	3'-5 3/8"	4'-0 1/2"	4'-5 3/8"	5'-0 3/8"	5'-5 3/8"	6'-0 3/8"
	(625)	(733)	(813)	(927)	(1051)	(1232)	(1356)	(1534)	(1660)	(1832)
Unobstructed Glass (single sash only)	19 5/16"	23 9/16"	26 11/16"	31 1/8"	36"	43 3/16"	48"	55 1/16"	60"	67 1/16"
	(491)	(598)	(678)	(791)	(914)	(1097)	(1219)	(1399)	(1524)	(1703)

continued on next page

CUSTOM SIZES AVAILABLE

CUSTOM SIZES AVAILABLE

1'-5" (432)	AR21	AR251	AR281	AR31	AR351	AR41	AR451	AR51	AR551	AR61
1'-8 1/2" (521)	AN21	AN251	AN281	AN31	AN351	AN41	AN451	AN51	AN551	AN61
2'-0 1/8" (613)	A21	A251	A281	A31	A351	A41	A451	A51	A551	A61
2'-4 3/8" (721)	AW21	AW251	AW281	AW31	AW351	AW41	AW451	AW51	AW551	AW61
2'-7 1/2" (800)	AX251	AX281	AX31	AX351	AX41	AX451	AX51	AX551		
2'-11 15/16" (913)			AXW281	AXW31	AXW351	AXW41	AXW451			
3'-4 3/8" (1035)										
3'-11 7/8" (1048)										
4'-0" (1219)										
4'-0 1/2" (1232)										
4'-4 13/16" (1108)										

Casement & Awning Windows

Window Dimension	2'-0 1/8" (613)	2'-11 15/16" (913)	2'-11 15/16" (913)	3'-4 13/16" (1037)	4'-0" (1219)	2'-0 1/8" (613)	2'-11 15/16" (913)
Minimum Rough Opening	2'-0 5/8" (625)	3'-0 1/2" (927)	3'-0 1/2" (927)	3'-5 3/8" (1051)	4'-0 1/2" (1232)	2'-0 5/8" (625)	3'-0 1/2" (927)

4'-0" (1219)	A212 (A21/A21)	A312 (A31/A31)	PA3050 (AXW31/A31)	PA3550 (AXW351/A351)	A213 (A21/A21/A21)	A313 (A31/A31/A31)
4'-0 1/2" (1232)						
4'-11 13/16" (1519)						
5'-0 3/8" (1534)						
5'-11 5/8" (1826)	AXW312 (AXW31/AXW31)	PA3060 (AP32V/A31)	PA3560 (AP352V/A351)	PA4060 (AP42V/A41)		
6'-0 1/8" (1832)						
5'-11 7/8" (1826)						
6'-0 3/8" (1838)						

• Window Dimension always refers to outside frame-to-frame dimension.
 • Minimum Rough Opening dimensions may need to be increased to allow for use of building wraps, flashing, sill panning, brackets, fasteners or other items.
 • Dimensions in parentheses are in millimeters.

Table of Sizes for Awning Windows With Triple-Pane Glass (continued)

Scale 1/8" (3) = 1'-0" (305) – 1:96

Window Dimension	4'-0" (1219)	4'-8 1/2" (1435)	5'-2 3/4" (1594)	5'-11 5/8" (1826)	5'-11 7/8" (1826)	7'-0 5/8" (2149)
Minimum Rough Opening	4'-0 1/2" (1232)	4'-9" (1448)	5'-3 1/4" (1607)	6'-0 1/8" (1832)	6'-0 3/8" (1838)	7'-1 1/8" (2162)
Unobstructed Glass <small>(single sash only)</small>	19 5/16" (491)	23 9/16" (598)	26 11/16" (678)	31 1/8" (1703)	19 5/16" (491)	23 9/16" (598)

1'-5" (432)	1'-5 1/2" (445)					
AR221	AR2251	AR2281	AR231	AR321	AR3251	
1'-8 1/2" (521)	1'-9" (533)	1'-9 1/2" (546)	1'-10 1/8" (560)	1'-10 3/8" (566)	1'-10 5/8" (572)	1'-11 1/8" (586)
AN221	AN2251	AN2281	AN231	AN321	AN3251	AN351
2'-0 1/8" (613)	2'-0 5/8" (625)	2'-0 7/8" (637)	2'-1 1/8" (651)	2'-1 3/8" (657)	2'-1 5/8" (663)	2'-1 7/8" (677)
A221	A2251	A2281	A231	A321	A3251	A351
2'-4 3/8" (721)	2'-4 7/8" (733)	2'-5 1/8" (747)	2'-5 5/8" (761)	2'-5 7/8" (767)	2'-6 1/8" (773)	2'-6 3/8" (779)
AW221	AW2251	AW2281	AW231	AW321	AW3251	AW351
2'-7 1/2" (800)	2'-8" (813)	2'-8 1/2" (827)	2'-9 1/8" (841)	2'-9 3/8" (847)	2'-9 5/8" (853)	2'-9 7/8" (859)
AX2251	AX2281	AX231				
2'-11 15/16" (913)	3'-0 1/2" (927)	3'-0 7/8" (941)	3'-1 1/8" (955)	3'-1 3/8" (961)	3'-1 5/8" (967)	3'-1 7/8" (973)
	AXW2281	AXW231				



Custom-size windows are available in 1/8" (3) increments. Windows can also be custom sized to match standard sizes ending in a 1/16" (1.5) of an inch. See pages 11-12.

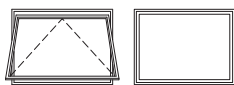

Venting Stationary

Choose venting or stationary. In addition to venting shown in table, other standard configurations are available for single, twin and triple windows.

Awning windows must be installed to vent as shown, and should not be rotated and used as a hopper.

Transom (CTR) windows (shown on pages 2-3) can be used over casement or awning windows, and may be rotated 90° and used as a sidelight with casement, awning or picture windows.

Available with either traditional or contemporary trim stops. Grille information shown on page 13. Details shown on pages 14-18.

• Window Dimension always refers to outside frame-to-frame dimension.
 • Minimum Rough Opening dimensions may need to be increased to allow for use of building wraps, flashing, sill panning, brackets, fasteners or other items.
 • Dimensions in parentheses are in millimeters.

400 SERIES WINDOWS WITH TRIPLE-PANE GLASS



Table of Sizes for Picture and Transom Windows With Triple-Pane Glass

Scale 1/8" (3) = 1'-0" (305) – 1:96

Unit Dimension	2'-11 15/16" (913)	3'-4 13/16" (1037)	4'-0" (1219)	4'-4 13/16" (1341)	4'-11 7/8" (1521)	5'-4 13/16" (1646)	5'-11 7/8" (1826)
Minimum Rough Opening	3'-0 1/2" (927)	3'-5 3/8" (1051)	4'-0 1/2" (1232)	4'-5 3/8" (1356)	5'-0 3/8" (1534)	5'-5 3/8" (1660)	6'-0 3/8" (1838)
Unobstructed Glass	31 1/8" (791)	36" (914)	43 3/16" (1097)	48" (1219)	55 1/16" (1399)	60" (1524)	67 1/16" (1703)

	CUSTOM WIDTHS – 36" to 71 7/8"						
1'-0" (305)							
1'-0 1/2" (318)							
7 3/16" (183)							
12"	CUSTOM WIDTHS – 35 15/16" to 59 7/8"						
2'-11 15/16" (913)							
3'-4 13/16" (1037)							
3'-5 3/8" (1051)							
36" (914)							
4'-0" (1219)							
4'-0 1/2" (1232)							
43 3/16" (1097)							
4'-4 13/16" (1341)							
4'-5 3/8" (1356)							
48" (1219)							
4'-11 7/8" (1521)							
5'-0 3/8" (1534)							
55 1/16" (1399)							
5'-4 13/16" (1646)							
5'-5 3/8" (1660)							
60" (1524)							
5'-11 7/8" (1826)							
6'-0 3/8" (1838)							
67 1/16" (1703)							



Custom-size windows are available in 1/8" (3) increments. Windows can also be custom sized to match standard sizes ending in a 1/16" (1.5) of an inch. See pages 11-12.

Picture (P) and transom (PTR) windows may be rotated 90° to align with casement or awning windows.

Available with either traditional or contemporary trim stops. Grille information shown on page 13. Details shown on pages 14-18.

Casement & Awning Windows

- Window Dimension always refers to outside frame-to-frame dimension.
- **Minimum Rough Opening dimensions may need to be increased to allow for use of building wraps, flashing, sill panning, brackets, fasteners or other items.**
- Dimensions in parentheses are in millimeters.

400 SERIES WINDOWS WITH TRIPLE-PANE GLASS



Area & Opening Specifications for Casement Windows With Triple-Pane Glass

Window Number	Clear Opening Area		Clear Opening in Full Open Position			Glass Area Sq. Ft./(m ²)	Vent Area		Top of Subfloor to Top of Inside Sill Stop Inches/(mm)	Overall Window Area Sq. Ft./(m ²)
	Hinge for Widest Clear Opening Sq. Ft./(m ²)	Hinge with Wash Mode Sq. Ft./(m ²)	Hinge for Widest Clear Opening Inches/(mm)	Hinge with Wash Mode Inches/(mm)	Height Inches/(mm)		Hinge for Widest Clear Opening Sq. Ft./(m ²)	Hinge with Wash Mode Sq. Ft./(m ²)		
CR12	—	1.0 (0.09)	—	7 5/16" (186)	19 1/4" (489)	1.7 (0.16)	—	1.5 (0.14)	60 9/16" (1538)	2.8 (0.26)
CR125	—	1.2 (0.11)	—	7 5/16" (186)	23 7/16" (595)	2.0 (0.19)	—	1.8 (0.17)	56 3/8" (1432)	3.3 (0.31)
CR13	—	1.6 (0.15)	—	7 5/16" (186)	31 1/16" (789)	2.7 (0.25)	—	2.4 (0.22)	48 3/4" (1238)	4.2 (0.39)
CR135	—	1.8 (0.17)	—	7 5/16" (186)	35 15/16" (913)	3.1 (0.29)	—	2.7 (0.25)	43 7/8" (1114)	4.8 (0.45)
CR14	—	2.2 (0.20)	—	7 5/16" (186)	43 1/8" (1095)	3.8 (0.35)	—	3.3 (0.31)	36 11/16" (932)	5.7 (0.53)
CR145	—	2.4 (0.22)	—	7 5/16" (186)	47 15/16" (1218)	4.2 (0.39)	—	3.6 (0.33)	31 7/8" (810)	6.2 (0.58)
CR15	—	2.8 (0.26)	—	7 5/16" (186)	55" (1397)	4.8 (0.45)	—	4.2 (0.39)	24 13/16" (630)	7.1 (0.66)
CR155	—	3.1 (0.29)	—	7 5/16" (186)	59 15/16" (1522)	5.2 (0.48)	—	4.5 (0.42)	19 7/8" (505)	7.7 (0.72)
CR16	—	3.4 (0.32)	—	7 5/16" (186)	67" (1702)	5.9 (0.55)	—	5.1 (0.47)	12 13/16" (325)	8.5 (0.79)
CR23	—	1.6 (0.15)	—	7 5/16" (186)	31 1/16" (789)	5.4 (0.50)	—	4.7 (0.44)	48 3/4" (1238)	8.4 (0.78)
CR235	—	1.8 (0.17)	—	7 5/16" (186)	35 15/16" (913)	6.3 (0.59)	—	5.4 (0.50)	43 7/8" (1114)	9.6 (0.89)
CR24	—	2.2 (0.20)	—	7 5/16" (186)	43 1/8" (1095)	7.6 (0.71)	—	6.5 (0.60)	36 11/16" (932)	11.3 (1.05)
CR245	—	2.4 (0.22)	—	7 5/16" (186)	47 15/16" (1218)	8.4 (0.78)	—	7.3 (0.68)	31 7/8" (810)	12.4 (1.15)
CR25	—	2.8 (0.26)	—	7 5/16" (186)	55" (1397)	9.6 (0.89)	—	8.3 (0.77)	24 13/16" (630)	14.2 (1.32)
CR255	—	3.1 (0.29)	—	7 5/16" (186)	59 15/16" (1522)	10.5 (0.98)	—	9.1 (0.85)	19 7/8" (505)	15.4 (1.43)
CR26	—	3.4 (0.32)	—	7 5/16" (186)	67" (1702)	11.7 (1.09)	—	10.2 (0.95)	12 13/16" (325)	17.0 (1.58)
CN12	—	1.5 (0.14)	—	10 13/16" (275)	19 1/4" (489)	2.2 (0.20)	—	1.9 (0.18)	60 9/16" (1538)	3.4 (0.32)
CN125	—	1.8 (0.17)	—	10 13/16" (275)	23 7/16" (595)	2.6 (0.24)	—	2.3 (0.21)	56 3/8" (1432)	4.0 (0.37)
CN13	—	2.3 (0.21)	—	10 13/16" (275)	31 1/16" (789)	3.5 (0.33)	—	3.1 (0.29)	48 3/4" (1238)	5.1 (0.47)
CN135	—	2.7 (0.25)	—	10 13/16" (275)	35 15/16" (913)	4.0 (0.37)	—	3.6 (0.33)	43 7/8" (1114)	5.8 (0.54)
CN14	—	3.2 (0.30)	—	10 13/16" (275)	43 1/8" (1095)	4.8 (0.45)	—	4.3 (0.40)	36 11/16" (932)	6.8 (0.63)
CN145	—	3.6 (0.33)	—	10 13/16" (275)	47 15/16" (1218)	5.4 (0.50)	—	4.8 (0.45)	31 7/8" (810)	7.5 (0.70)
CN15	—	4.1 (0.38)	—	10 13/16" (275)	55" (1397)	6.2 (0.58)	—	5.5 (0.51)	24 13/16" (630)	8.5 (0.79)
CN155	—	4.5 (0.42)	—	10 13/16" (275)	59 15/16" (1522)	6.7 (0.62)	—	6.0 (0.56)	19 7/8" (505)	9.2 (0.86)
CN16	—	5.0 (0.47)	—	10 13/16" (275)	67" (1702)	7.5 (0.70)	—	6.7 (0.62)	12 13/16" (325)	10.2 (0.95)
CN22	—	1.5 (0.14)	—	10 13/16" (275)	19 1/4" (489)	4.4 (0.41)	—	3.8 (0.35)	60 9/16" (1538)	6.8 (0.63)
CN225	—	1.8 (0.17)	—	10 13/16" (275)	23 7/16" (595)	5.2 (0.48)	—	4.6 (0.43)	56 3/8" (1432)	8.0 (0.74)
CN23	—	2.3 (0.21)	—	10 13/16" (275)	31 1/16" (789)	7.0 (0.65)	—	6.2 (0.58)	48 3/4" (1238)	10.2 (0.95)
CN235	—	2.7 (0.25)	—	10 13/16" (275)	35 15/16" (913)	8.0 (0.74)	—	7.2 (0.67)	43 7/8" (1114)	11.5 (1.07)
CN24	—	3.2 (0.30)	—	10 13/16" (275)	43 1/8" (1095)	9.7 (0.90)	—	8.6 (0.80)	36 11/16" (932)	13.6 (1.26)
CN245	—	3.6 (0.33)	—	10 13/16" (275)	47 15/16" (1218)	10.7 (0.99)	—	9.6 (0.89)	31 7/8" (810)	15.0 (1.39)
CN25	—	4.1 (0.38)	—	10 13/16" (275)	55" (1397)	12.3 (1.14)	—	11.0 (1.02)	24 13/16" (630)	16.9 (1.57)
CN255	—	4.5 (0.42)	—	10 13/16" (275)	59 15/16" (1522)	13.4 (1.25)	—	12.0 (1.12)	19 7/8" (505)	18.4 (1.71)
CN26	—	5.0 (0.47)	—	10 13/16" (275)	67" (1702)	15.0 (1.39)	—	13.4 (1.25)	12 13/16" (325)	20.3 (1.89)
CN32	—	1.5 (0.14)	—	10 13/16" (275)	19 1/4" (489)	6.6 (0.61)	—	3.8 (0.35)	60 9/16" (1538)	10.2 (0.95)
CN325	—	1.8 (0.17)	—	10 13/16" (275)	23 7/16" (595)	7.8 (0.73)	—	4.6 (0.43)	56 3/8" (1432)	12.0 (1.12)
CN33	—	2.3 (0.21)	—	10 13/16" (275)	31 1/16" (789)	10.5 (0.98)	—	6.2 (0.58)	48 3/4" (1238)	15.3 (1.42)
CN335	—	2.7 (0.25)	—	10 13/16" (275)	35 15/16" (913)	12.0 (1.12)	—	7.2 (0.67)	43 7/8" (1114)	17.4 (1.62)
CN34	—	3.2 (0.30)	—	10 13/16" (275)	43 1/8" (1095)	14.4 (1.34)	—	8.6 (0.80)	36 11/16" (932)	20.4 (1.90)
CN345	—	3.6 (0.33)	—	10 13/16" (275)	47 15/16" (1218)	16.2 (1.51)	—	9.6 (0.89)	31 7/8" (810)	22.5 (2.09)
CN35	—	4.1 (0.38)	—	10 13/16" (275)	55" (1397)	18.6 (1.73)	—	11.0 (1.02)	24 13/16" (630)	25.5 (2.37)
CN355	—	4.5 (0.42)	—	10 13/16" (275)	59 15/16" (1522)	20.1 (1.87)	—	12.0 (1.11)	19 7/8" (505)	27.6 (2.57)
CN36	—	5.0 (0.47)	—	10 13/16" (275)	67" (1702)	22.5 (2.09)	—	13.4 (1.24)	12 13/16" (325)	30.6 (2.84)
C12	—	1.9 (0.18)	—	14 7/16" (367)	19 1/4" (489)	2.6 (0.24)	—	2.4 (0.22)	60 9/16" (1538)	4.0 (0.37)
C125	—	2.4 (0.22)	—	14 7/16" (367)	23 7/16" (595)	3.2 (0.30)	—	2.9 (0.27)	56 3/8" (1432)	4.7 (0.44)
C13	—	3.1 (0.29)	—	14 7/16" (367)	31 1/16" (789)	4.3 (0.40)	—	3.9 (0.36)	48 3/4" (1238)	6.0 (0.56)
C135	—	3.6 (0.33)	—	14 7/16" (367)	35 15/16" (913)	4.9 (0.46)	—	4.5 (0.42)	43 7/8" (1114)	6.8 (0.63)
C14	—	4.3 (0.40)	—	14 7/16" (367)	43 1/8" (1095)	5.9 (0.55)	—	5.4 (0.50)	36 11/16" (932)	8.0 (0.74)
C145	—	4.8 (0.45)	—	14 7/16" (367)	47 15/16" (1218)	6.6 (0.61)	—	6.0 (0.56)	31 7/8" (810)	8.8 (0.82)
C15	—	5.5 (0.51)	—	14 7/16" (367)	55" (1397)	7.5 (0.70)	—	6.9 (0.64)	24 13/16" (630)	10.0 (0.93)
C155	—	6.0 (0.56)	—	14 7/16" (367)	59 15/16" (1522)	8.2 (0.76)	—	7.5 (0.70)	19 7/8" (505)	10.9 (1.01)
C16	—	6.7 (0.62)	—	14 7/16" (367)	67" (1702)	9.2 (0.86)	—	8.4 (0.78)	12 13/16" (325)	12.0 (1.12)
C22	—	1.9 (0.18)	—	14 7/16" (367)	19 1/4" (489)	5.2 (0.48)	—	4.8 (0.45)	60 9/16" (1538)	8.0 (0.74)
C225	—	2.4 (0.22)	—	14 7/16" (367)	23 7/16" (595)	6.4 (0.59)	—	5.8 (0.54)	56 3/8" (1432)	9.4 (0.87)
C23	—	3.1 (0.29)	—	14 7/16" (367)	31 1/16" (789)	8.5 (0.79)	—	7.8 (0.73)	48 3/4" (1238)	12.0 (1.12)
C235	—	3.6 (0.33)	—	14 7/16" (367)	35 15/16" (913)	9.9 (0.92)	—	9.0 (0.84)	43 7/8" (1114)	13.6 (1.26)
C24	—	4.3 (0.40)	—	14 7/16" (367)	43 1/8" (1095)	11.8 (1.10)	—	10.8 (1.00)	36 11/16" (932)	16.0 (1.49)
C245	—	4.8 (0.45)	—	14 7/16" (367)	47 15/16" (1218)	13.1 (1.22)	—	12.0 (1.12)	31 7/8" (810)	17.6 (1.64)
C25	—	5.5 (0.51)	—	14 7/16" (367)	55" (1397)	15.1 (1.40)	—	13.8 (1.28)	24 13/16" (630)	20.0 (1.86)

• Top of Subfloor to Top of Inside Sill Stop is calculated based upon a structural header height of 6'-10 1/2" (2096).
 • Dimensions in parentheses are in millimeters or square meters.

continued on next page

Casement & Awning Windows

400 SERIES WINDOWS WITH TRIPLE-PANE GLASS



Area & Opening Specifications for Casement Windows With Triple-Pane Glass (continued)

Window Number	Clear Opening Area		Clear Opening in Full Open Position			Glass Area Sq. Ft./ (m ²)	Vent Area		Top of Subfloor to Top of Inside Sill Stop Inches/(mm)	Overall Window Area Sq. Ft./ (m ²)
	Hinge for Widest Clear Opening Sq. Ft./ (m ²)	Hinge with Wash Mode Sq. Ft./ (m ²)	Hinge for Widest Clear Opening Inches/(mm)	Hinge with Wash Mode Inches/(mm)	Height Inches/(mm)		Hinge for Widest Clear Opening Sq. Ft./ (m ²)	Hinge with Wash Mode Sq. Ft./ (m ²)		
C255	—	6.0 (0.56)	—	14 7/16" (367)	59 15/16" (1522)	16.4 (1.52)	—	15.0 (1.39)	19 7/8" (505)	21.6 (2.01)
C26	—	6.7 (0.62)	—	14 7/16" (367)	67" (1702)	18.4 (1.71)	—	16.8 (1.56)	12 13/16" (325)	24.0 (2.23)
C32	—	1.9 (0.18)	—	14 7/16" (367)	19 1/4" (489)	7.8 (0.73)	—	4.8 (0.45)	60 9/16" (1538)	12.0 (1.12)
C325	—	2.4 (0.22)	—	14 7/16" (367)	23 7/16" (595)	9.6 (0.89)	—	5.8 (0.54)	56 3/8" (1432)	14.1 (1.31)
C33	—	3.1 (0.29)	—	14 7/16" (367)	31 1/16" (789)	12.8 (1.19)	—	7.8 (0.73)	48 3/4" (1238)	17.9 (1.66)
C335	—	3.6 (0.33)	—	14 7/16" (367)	35 15/16" (913)	14.8 (1.38)	—	9.0 (0.84)	43 7/8" (1114)	20.4 (1.90)
C34	—	4.3 (0.40)	—	14 7/16" (367)	43 1/8" (1095)	17.7 (1.64)	—	10.8 (1.00)	36 11/16" (932)	24.0 (2.23)
C345	—	4.8 (0.45)	—	14 7/16" (367)	47 15/16" (1218)	19.7 (1.83)	—	12.0 (1.12)	31 7/8" (810)	26.4 (2.45)
C35	—	5.5 (0.51)	—	14 7/16" (367)	55" (1397)	22.6 (2.10)	—	13.8 (1.28)	24 13/16" (630)	29.9 (2.78)
CW12	—	2.5 (0.23)	—	18 11/16" (475)	19 1/4" (489)	3.2 (0.30)	—	3.0 (0.28)	60 9/16" (1538)	4.8 (0.45)
CW125	—	3.0 (0.28)	—	18 11/16" (475)	23 7/16" (595)	3.9 (0.36)	—	3.6 (0.33)	56 3/8" (1432)	5.6 (0.52)
CW13	—	4.0 (0.37)	—	18 11/16" (475)	31 1/16" (789)	5.2 (0.48)	—	4.8 (0.45)	48 3/4" (1238)	7.1 (0.66)
CW1350*	5.7 (0.53)	5.1 (0.47)	22 9/16" (573)	20" (508)	36 3/8" (924)	6.0 (0.56)	5.7 (0.53)	5.5 (0.51)	43 7/8" (1114)	8.0 (0.74)
CW140	—	6.0 (0.56)	—	20" (508)	43 1/8" (1095)	7.2 (0.67)	—	6.6 (0.61)	36 11/16" (932)	9.5 (0.88)
CW1450	—	6.7 (0.62)	—	20" (508)	47 15/16" (1218)	8.0 (0.74)	—	7.3 (0.68)	31 7/8" (810)	10.4 (0.97)
CW150	—	7.6 (0.71)	—	20" (508)	55" (1397)	9.2 (0.86)	—	8.4 (0.78)	24 13/16" (630)	11.8 (1.10)
CW1550	—	8.3 (0.77)	—	20" (508)	59 15/16" (1522)	10.0 (0.93)	—	9.1 (0.85)	19 7/8" (505)	12.8 (1.19)
CW160	—	9.3 (0.86)	—	20" (508)	67" (1702)	11.2 (1.04)	—	10.2 (0.95)	12 13/16" (325)	14.2 (1.32)
CW22	—	2.5 (0.23)	—	18 11/16" (475)	19 1/4" (489)	6.4 (0.59)	—	6.0 (0.56)	60 9/16" (1538)	9.6 (0.89)
CW225	—	3.0 (0.28)	—	18 11/16" (475)	23 7/16" (595)	7.8 (0.72)	—	7.2 (0.67)	56 3/8" (1432)	11.2 (1.04)
CW23	—	4.0 (0.37)	—	18 11/16" (475)	31 1/16" (789)	10.4 (0.97)	—	9.6 (0.89)	48 3/4" (1238)	14.1 (1.31)
CW2350*	5.7 (0.53)	5.1 (0.47)	22 9/16" (573)	20" (508)	36 3/8" (924)	12.0 (1.12)	11.4 (1.06)	11.1 (1.03)	43 7/8" (1114)	16.0 (1.49)
CW240	—	6.0 (0.56)	—	20" (508)	43 1/8" (1095)	14.4 (1.34)	—	13.1 (1.22)	36 11/16" (932)	18.8 (1.75)
CW2450	—	6.7 (0.62)	—	20" (508)	47 15/16" (1218)	16.0 (1.49)	—	14.6 (1.36)	31 7/8" (810)	20.8 (1.93)
CW250	—	7.6 (0.71)	—	20" (508)	55" (1397)	18.3 (1.70)	—	16.7 (1.55)	24 13/16" (630)	23.5 (2.18)
CW2550	—	8.3 (0.77)	—	20" (508)	59 15/16" (1522)	20.0 (1.86)	—	18.2 (1.69)	19 7/8" (505)	25.6 (2.38)
CW260	—	9.3 (0.86)	—	20" (508)	67" (1702)	22.3 (2.07)	—	20.4 (1.90)	12 13/16" (325)	28.2 (2.62)
CW32	—	2.5 (0.23)	—	18 11/16" (475)	19 1/4" (489)	9.6 (0.89)	—	6.0 (0.56)	60 9/16" (1538)	14.4 (1.34)
CW325	—	3.0 (0.28)	—	18 11/16" (475)	23 7/16" (595)	11.7 (1.09)	—	7.2 (0.67)	56 3/8" (1432)	16.8 (1.56)
CW33	—	4.0 (0.37)	—	18 11/16" (475)	31 1/16" (789)	15.6 (1.45)	—	9.6 (0.89)	48 3/4" (1238)	21.1 (1.96)
CW3350*	5.7 (0.53)	5.1 (0.47)	22 9/16" (567)	20" (508)	36 3/8" (924)	18.0 (1.67)	11.4 (1.06)	11.1 (1.03)	43 7/8" (1114)	24.0 (2.23)
CW340	—	6.0 (0.56)	—	20" (508)	43 1/8" (1095)	21.6 (2.01)	—	13.1 (1.22)	36 11/16" (932)	28.2 (2.62)
CW3450	—	6.7 (0.62)	—	20" (508)	47 15/16" (1218)	24.0 (2.23)	—	14.6 (1.36)	31 7/8" (810)	31.0 (2.88)
CW350	—	7.6 (0.71)	—	20" (508)	55" (1397)	27.6 (2.56)	—	16.7 (1.55)	24 13/16" (630)	35.2 (3.27)
CX125	—	3.5 (0.33)	—	21 13/16" (554)	23 7/16" (595)	4.4 (0.41)	—	4.1 (0.38)	56 3/8" (1432)	6.2 (0.58)
CX13	—	4.7 (0.44)	—	21 13/16" (554)	31 1/16" (789)	5.9 (0.54)	—	5.4 (0.51)	48 3/4" (1238)	7.9 (0.73)
CX1350	—	5.4 (0.51)	—	21 13/16" (554)	35 15/16" (913)	6.8 (0.63)	—	6.3 (0.59)	43 7/8" (1114)	8.9 (0.83)
CX140	—	6.5 (0.61)	—	21 13/16" (554)	43 1/8" (1095)	8.1 (0.76)	—	7.6 (0.70)	36 11/16" (932)	10.5 (0.98)
CX1450	—	7.3 (0.67)	—	21 13/16" (554)	47 15/16" (1218)	9.0 (0.84)	—	8.4 (0.78)	31 7/8" (810)	11.6 (1.07)
CX150	—	8.3 (0.77)	—	21 13/16" (554)	55" (1397)	10.4 (0.96)	—	9.7 (0.90)	24 13/16" (630)	13.1 (1.22)
CX1550	—	9.1 (0.84)	—	21 13/16" (554)	59 15/16" (1522)	11.3 (1.05)	—	10.5 (0.98)	19 7/8" (505)	14.2 (1.32)
CX23	—	4.7 (0.44)	—	21 13/16" (554)	31 1/16" (789)	11.7 (1.09)	—	10.9 (1.01)	48 3/4" (1238)	15.7 (1.46)
CX2350	—	5.4 (0.51)	—	21 13/16" (554)	35 15/16" (913)	13.6 (1.26)	—	12.6 (1.17)	43 7/8" (1114)	17.8 (1.65)
CX240	—	6.5 (0.61)	—	21 13/16" (554)	43 1/8" (1095)	16.3 (1.51)	—	15.1 (1.41)	36 11/16" (932)	20.9 (1.94)
CX2450	—	7.3 (0.67)	—	21 13/16" (554)	47 15/16" (1218)	18.1 (1.68)	—	16.8 (1.56)	31 7/8" (810)	23.0 (2.14)
CX250	—	8.3 (0.77)	—	21 13/16" (554)	55" (1397)	20.7 (1.93)	—	19.3 (1.79)	24 13/16" (630)	26.1 (2.42)
CXW130	—	5.6 (0.53)	—	26 1/4" (667)	31 1/16" (789)	6.8 (0.63)	—	6.1 (0.57)	48 3/4" (1238)	9.0 (0.84)
CXW1350	—	6.6 (0.61)	—	26 1/4" (667)	35 15/16" (913)	7.9 (0.73)	—	7.0 (0.65)	43 7/8" (1114)	10.2 (0.95)
CXW140	—	7.9 (0.73)	—	26 1/4" (667)	43 1/8" (1095)	9.5 (0.88)	—	8.4 (0.78)	36 11/16" (932)	12.0 (1.12)
CXW1450	—	8.8 (0.82)	—	26 1/4" (667)	47 15/16" (1218)	10.5 (0.98)	—	9.4 (0.87)	31 7/8" (810)	13.2 (1.23)
CXW23	—	5.6 (0.53)	—	26 1/4" (667)	31 1/16" (789)	13.6 (1.26)	—	12.2 (0.57)	48 3/4" (1238)	17.9 (1.66)
CXW2350	—	6.5 (0.61)	—	26 1/4" (667)	35 15/16" (913)	15.8 (1.47)	—	14.0 (0.57)	43 7/8" (1114)	20.3 (1.89)
CXW240	—	7.9 (0.73)	—	26 1/4" (667)	43 1/8" (1095)	19.0 (1.77)	—	16.8 (0.57)	36 11/16" (932)	23.9 (2.22)
CXW2450	—	8.7 (0.81)	—	26 1/4" (667)	47 15/16" (1218)	21.0 (1.95)	—	18.8 (0.57)	31 7/8" (810)	26.3 (2.44)

*Top of Subfloor to Top of Inside Sill Stop is calculated based upon a structural header height of 6'-10 1/2" (2096).
 •Dimensions in parentheses are in millimeters or square meters.
 ◊Meets or exceeds clear opening area of 5.7 sq. ft. or 0.53 m², clear opening width of 20" (508) and clear opening height of 24" (610) with appropriate hinge specified.
 *Available with straight-arm operator (hinged for widest clear opening) which meets clear opening width of 22" (599).

Casement & Awning Windows

400 SERIES WINDOWS WITH TRIPLE-PANE GLASS



Area & Opening Specifications for Awning Windows With Triple-Pane Glass

Window Number	Clear Opening Area Sq. Ft./ (m ²)	Clear Opening in Full Open Position		Glass Area Sq. Ft./ (m ²)	Vent Area Sq. Ft./ (m ²)	Top of Subfloor to Top of Inside Sill Stop Inches/(mm)	Overall Window Area Sq. Ft./ (m ²)
		Width Inches/(mm)	Depth Inches/(mm)				
AR21	0.9 (0.08)	19 1/2" (495)	6 3/8" (162)	1.7 (0.16)	0.9 (0.08)	67 7/16" (1713)	2.8 (0.26)
AR251	1.1 (0.10)	23 3/4" (603)	6 3/8" (162)	2.0 (0.19)	1.1 (0.10)	67 7/16" (1713)	3.3 (0.31)
AR281	1.2 (0.11)	26 7/8" (683)	6 3/8" (162)	2.3 (0.21)	1.2 (0.11)	67 7/16" (1713)	3.7 (0.34)
AR31	1.4 (0.13)	31 5/16" (795)	6 3/8" (162)	2.7 (0.25)	1.4 (0.13)	67 7/16" (1713)	4.2 (0.39)
AR351	1.6 (0.15)	36 3/16" (919)	6 3/8" (162)	3.1 (0.29)	1.6 (0.15)	67 7/16" (1713)	4.8 (0.45)
AR41	1.9 (0.18)	43 3/8" (1102)	6 3/8" (162)	3.8 (0.35)	1.9 (0.18)	67 7/16" (1713)	5.7 (0.53)
AR451	2.1 (0.20)	48 3/16" (1224)	6 3/8" (162)	4.2 (0.39)	2.1 (0.20)	67 7/16" (1713)	6.2 (0.58)
AR51	2.5 (0.23)	55 1/2" (1410)	6 3/8" (162)	4.8 (0.45)	2.5 (0.23)	67 7/16" (1713)	7.1 (0.66)
AR551	2.7 (0.25)	60 3/16" (1529)	6 3/8" (162)	5.2 (0.48)	2.7 (0.25)	67 7/16" (1713)	7.7 (0.72)
AR61	3.0 (0.28)	67 1/2" (1715)	6 3/8" (162)	5.9 (0.55)	3.0 (0.28)	67 7/16" (1713)	8.5 (0.79)
AR221	0.9 (0.08)	19 1/2" (495)	6 3/8" (162)	3.4 (0.32)	1.7 (0.16)	67 7/16" (1713)	5.6 (0.52)
AR2251	1.1 (0.10)	23 3/4" (603)	6 3/8" (162)	4.0 (0.37)	2.1 (0.20)	67 7/16" (1713)	6.6 (0.61)
AR2281	1.2 (0.11)	26 7/8" (683)	6 3/8" (162)	4.6 (0.43)	2.4 (0.22)	67 7/16" (1713)	7.4 (0.69)
AR231	1.4 (0.13)	31 5/16" (795)	6 3/8" (162)	5.4 (0.50)	2.8 (0.26)	67 7/16" (1713)	8.4 (0.78)
AR321	0.9 (0.08)	19 1/2" (495)	6 3/8" (162)	5.1 (0.47)	2.6 (0.24)	67 7/16" (1713)	8.4 (0.78)
AR3251	1.1 (0.10)	23 3/4" (603)	6 3/8" (162)	6.0 (0.56)	3.2 (0.29)	67 7/16" (1713)	9.9 (0.92)
AN21	0.9 (0.08)	19 1/2" (495)	6 7/16" (164)	2.2 (0.20)	0.9 (0.08)	63 15/16" (1624)	3.4 (0.32)
AN251	1.1 (0.10)	23 3/4" (603)	6 7/16" (164)	2.6 (0.24)	1.1 (0.10)	63 15/16" (1624)	4.0 (0.37)
AN281	1.2 (0.11)	26 7/8" (683)	6 7/16" (164)	3.0 (0.28)	1.2 (0.11)	63 15/16" (1624)	4.5 (0.42)
AN31	1.4 (0.13)	31 5/16" (795)	6 7/16" (164)	3.5 (0.33)	1.4 (0.13)	63 15/16" (1624)	5.1 (0.47)
AN351	1.6 (0.15)	36 3/16" (919)	6 7/16" (164)	4.0 (0.37)	1.6 (0.15)	63 15/16" (1624)	5.8 (0.54)
AN41	1.9 (0.18)	43 3/8" (1102)	6 7/16" (164)	4.8 (0.45)	1.9 (0.18)	63 15/16" (1624)	6.8 (0.63)
AN451	2.2 (0.20)	48 3/16" (1224)	6 7/16" (164)	5.4 (0.50)	2.2 (0.20)	63 15/16" (1624)	7.5 (0.70)
AN51	2.5 (0.23)	55 1/2" (1410)	6 7/16" (164)	6.2 (0.58)	2.5 (0.23)	63 15/16" (1624)	8.5 (0.79)
AN551	2.7 (0.25)	60 3/16" (1529)	6 7/16" (164)	6.7 (0.62)	2.7 (0.25)	63 15/16" (1624)	9.2 (0.86)
AN61	3.0 (0.28)	67 1/2" (1715)	6 7/16" (164)	7.5 (0.70)	3.0 (0.28)	63 15/16" (1624)	10.2 (0.95)
AN221	0.9 (0.08)	19 1/2" (495)	6 7/16" (164)	4.4 (0.41)	1.7 (0.16)	63 15/16" (1624)	6.8 (0.63)
AN2251	1.1 (0.10)	23 3/4" (603)	6 7/16" (164)	5.2 (0.48)	2.1 (0.20)	63 15/16" (1624)	8.0 (0.74)
AN2281	1.2 (0.11)	26 7/8" (683)	6 7/16" (164)	6.0 (0.56)	2.4 (0.22)	63 15/16" (1624)	9.0 (0.84)
AN231	1.4 (0.13)	31 5/16" (795)	6 7/16" (164)	7.0 (0.65)	2.8 (0.26)	63 15/16" (1624)	10.2 (0.95)
AN321	0.9 (0.08)	19 1/2" (495)	6 7/16" (164)	6.6 (0.61)	2.6 (0.24)	63 15/16" (1624)	10.2 (0.95)
AN3251	1.1 (0.10)	23 3/4" (603)	6 7/16" (164)	7.8 (0.73)	3.2 (0.30)	63 15/16" (1624)	12.0 (1.12)
A21	0.9 (0.08)	19 1/2" (495)	6 1/2" (165)	2.6 (0.24)	0.9 (0.08)	60 5/16" (1532)	4.0 (0.37)
A251	1.1 (0.10)	23 3/4" (603)	6 1/2" (165)	3.2 (0.30)	1.1 (0.10)	60 5/16" (1532)	4.8 (0.45)
A281	1.2 (0.11)	26 7/8" (683)	6 1/2" (165)	3.7 (0.34)	1.2 (0.11)	60 5/16" (1532)	5.3 (0.49)
A31	1.4 (0.13)	31 5/16" (795)	6 1/2" (165)	4.3 (0.40)	1.4 (0.13)	60 5/16" (1532)	6.0 (0.56)
A351	1.6 (0.15)	36 3/16" (919)	6 1/2" (165)	4.9 (0.46)	1.6 (0.15)	60 5/16" (1532)	6.8 (0.63)
A41	2.0 (0.18)	43 3/8" (1102)	6 1/2" (165)	5.9 (0.55)	2.0 (0.18)	60 5/16" (1532)	8.0 (0.74)
A451	2.2 (0.20)	48 3/16" (1224)	6 1/2" (165)	6.6 (0.61)	2.2 (0.20)	60 5/16" (1532)	8.8 (0.82)
A51	2.5 (0.23)	55 1/2" (1410)	6 1/2" (165)	7.5 (0.70)	2.5 (0.23)	60 5/16" (1532)	10.0 (0.93)
A551	2.7 (0.25)	60 3/16" (1529)	6 1/2" (165)	8.2 (0.76)	2.7 (0.25)	60 5/16" (1532)	10.9 (1.01)
A61	3.0 (0.28)	67 1/2" (1715)	6 1/2" (165)	9.2 (0.86)	3.0 (0.28)	60 5/16" (1532)	12.0 (1.12)
A221	0.9 (0.08)	19 1/2" (495)	6 1/2" (165)	5.2 (0.48)	1.8 (0.16)	60 5/16" (1532)	8.0 (0.74)
A2251	1.1 (0.10)	23 3/4" (603)	6 1/2" (165)	6.4 (0.60)	2.1 (0.20)	60 5/16" (1532)	9.6 (0.89)
A2281	1.2 (0.11)	26 7/8" (683)	6 1/2" (165)	7.4 (0.69)	2.4 (0.23)	60 5/16" (1532)	10.6 (0.99)
A231	1.4 (0.13)	31 5/16" (795)	6 1/2" (165)	8.6 (0.80)	2.8 (0.26)	60 5/16" (1532)	12.0 (1.12)
A321	0.9 (0.08)	19 1/2" (495)	6 1/2" (165)	7.8 (0.73)	2.6 (0.25)	60 5/16" (1532)	12.0 (1.12)
A3251	1.1 (0.10)	23 3/4" (603)	6 1/2" (165)	9.6 (0.89)	3.2 (0.30)	60 5/16" (1532)	14.4 (1.34)
AW21	0.9 (0.08)	19 1/2" (495)	6 1/2" (165)	3.2 (0.30)	0.9 (0.08)	56 1/16" (1424)	4.8 (0.45)
AW251	1.1 (0.10)	23 3/4" (603)	6 1/2" (165)	3.9 (0.36)	1.1 (0.10)	56 1/16" (1424)	5.6 (0.52)
AW281	1.2 (0.11)	26 7/8" (683)	6 1/2" (165)	4.4 (0.41)	1.2 (0.11)	56 1/16" (1424)	6.2 (0.58)
AW31	1.4 (0.13)	31 5/16" (795)	6 1/2" (165)	5.2 (0.48)	1.4 (0.13)	56 1/16" (1424)	7.1 (0.66)
AW351	1.6 (0.15)	36 3/16" (919)	6 1/2" (165)	6.0 (0.56)	1.6 (0.15)	56 1/16" (1424)	8.0 (0.74)
AW41	2.0 (0.18)	43 3/8" (1102)	6 1/2" (165)	7.2 (0.67)	2.0 (0.18)	56 1/16" (1424)	9.5 (0.88)
AW451	2.2 (0.20)	48 3/16" (1224)	6 1/2" (165)	8.0 (0.74)	2.2 (0.20)	56 1/16" (1424)	10.4 (0.97)
AW51	2.5 (0.23)	55 1/2" (1410)	6 1/2" (165)	9.2 (0.86)	2.5 (0.23)	56 1/16" (1424)	11.8 (1.10)
AW551	2.7 (0.25)	60 3/16" (1529)	6 1/2" (165)	10.0 (0.93)	2.7 (0.25)	56 1/16" (1424)	12.8 (1.19)
AW61	3.0 (0.28)	67 1/2" (1715)	6 1/2" (165)	11.2 (1.04)	3.0 (0.28)	56 1/16" (1424)	14.2 (1.32)
AW221	0.9 (0.08)	19 1/2" (495)	6 1/2" (165)	6.4 (0.60)	1.8 (0.16)	56 1/16" (1424)	9.6 (0.89)

• Top of Subfloor to Top of Inside Sill Stop is calculated based upon a structural header height of 6'-10 1/2" (2096). continued on next page
 • Dimensions in parentheses are in millimeters or square meters.

Casement & Awning Windows

400 SERIES WINDOWS WITH TRIPLE-PANE GLASS



Area & Opening Specifications for Awning Windows With Triple-Pane Glass *(continued)*

Window Number	Clear Opening Area Sq. Ft./ (m ²)	Clear Opening in Full Open Position		Glass Area Sq. Ft./ (m ²)	Vent Area Sq. Ft./ (m ²)	Top of Subfloor to Top of Inside Sill Stop Inches/ (mm)	Overall Window Area Sq. Ft./ (m ²)
		Width Inches/ (mm)	Depth Inches/ (mm)				
AW2251	1.1 (0.10)	23 3/4" (603)	6 1/2" (165)	7.8 (0.73)	2.1 (0.20)	56 1/16" (1424)	11.2 (1.04)
AW2281	1.2 (0.11)	26 7/8" (683)	6 1/2" (165)	8.8 (0.82)	2.4 (0.23)	56 1/16" (1424)	12.4 (1.15)
AW231	1.4 (0.13)	31 5/16" (795)	6 1/2" (165)	10.4 (0.97)	2.8 (0.26)	56 1/16" (1424)	14.2 (1.32)
AW321	0.9 (0.08)	19 1/2" (495)	6 1/2" (165)	9.6 (0.89)	2.6 (0.25)	56 1/16" (1424)	14.4 (1.34)
AW3251	1.1 (0.10)	23 3/4" (603)	6 1/2" (165)	11.7 (1.09)	3.2 (0.30)	56 1/16" (1424)	16.8 (1.56)
AX251	1.1 (0.10)	23 3/4" (603)	6 1/2" (165)	4.4 (0.41)	1.1 (0.10)	53 15/16" (1370)	6.2 (0.58)
AX281	1.2 (0.11)	26 7/8" (683)	6 1/2" (165)	5.0 (0.47)	1.2 (0.11)	53 15/16" (1370)	6.9 (0.64)
AX31	1.4 (0.13)	31 5/16" (795)	6 1/2" (165)	5.9 (0.54)	1.4 (0.13)	53 15/16" (1370)	7.9 (0.73)
AX351	1.6 (0.15)	36 3/16" (919)	6 1/2" (165)	6.8 (0.63)	1.6 (0.15)	53 15/16" (1370)	8.9 (0.83)
AX41	2.0 (0.18)	43 3/8" (1102)	6 1/2" (165)	8.1 (0.76)	2.0 (0.18)	53 15/16" (1370)	10.5 (0.98)
AX451	2.2 (0.20)	48 3/16" (1224)	6 1/2" (165)	9.0 (0.84)	2.2 (0.20)	53 15/16" (1370)	11.6 (1.07)
AX51	2.5 (0.23)	55 1/2" (1410)	6 1/2" (165)	10.4 (0.96)	2.5 (0.23)	53 15/16" (1370)	13.1 (1.22)
AX551	2.7 (0.25)	60 3/16" (1529)	6 1/2" (165)	11.3 (1.05)	2.7 (0.25)	53 15/16" (1370)	14.2 (1.32)
AX2251	1.1 (0.10)	23 3/4" (603)	6 1/2" (165)	8.9 (0.82)	2.1 (0.20)	53 15/16" (1370)	12.4 (1.15)
AX2281	1.2 (0.11)	26 7/8" (683)	6 1/2" (165)	10.0 (0.93)	2.4 (0.23)	53 15/16" (1370)	13.8 (1.28)
AX231	1.4 (0.13)	31 5/16" (795)	6 1/2" (165)	11.7 (1.09)	2.8 (0.26)	53 15/16" (1370)	15.7 (1.46)
AX3251	1.1 (0.10)	23 3/4" (603)	6 1/2" (165)	13.3 (1.24)	3.2 (0.30)	53 15/16" (1370)	18.6 (1.73)
AXW281	1.2 (0.11)	26 7/8" (683)	6 1/2" (165)	5.8 (0.54)	1.2 (0.11)	48 1/2" (1232)	7.9 (0.73)
AXW31	1.4 (0.13)	31 5/16" (795)	6 1/2" (165)	6.8 (0.63)	1.4 (0.13)	48 1/2" (1232)	9.0 (0.84)
AXW351	1.6 (0.15)	36 3/16" (919)	6 1/2" (165)	7.9 (0.73)	1.6 (0.15)	48 1/2" (1232)	10.2 (0.95)
AXW41	2.0 (0.18)	43 3/8" (1102)	6 1/2" (165)	9.5 (0.88)	2.0 (0.18)	48 1/2" (1232)	12.0 (1.12)
AXW451	2.2 (0.20)	48 3/16" (1224)	6 1/2" (165)	10.5 (0.98)	2.2 (0.20)	48 1/2" (1232)	13.2 (1.23)
AXW2281	1.2 (0.11)	26 7/8" (683)	6 1/2" (165)	11.6 (1.08)	2.4 (0.23)	48 1/2" (1232)	15.8 (1.47)
AXW231	1.4 (0.13)	31 5/16" (795)	6 1/2" (165)	13.6 (1.26)	2.8 (0.26)	48 1/2" (1232)	18.0 (1.67)
A335*	1.4 (0.13)	31 5/16" (795)	6 1/2" (676)	7.0 (0.65)	1.3 (0.12)	43 11/16" (1110)	10.2 (0.95)
A3535	1.6 (0.14)	36 3/16" (943)	6 1/2" (165)	8.1 (0.75)	1.6 (0.15)	43 11/16" (1110)	11.5 (1.07)
AP32V	1.4 (0.12)	31 5/16" (795)	6 1/2" (165)	9.4 (0.87)	1.4 (0.13)	36 7/16" (926)	12.0 (1.12)
AP352V	1.6 (0.14)	36 3/16" (919)	6 1/2" (165)	10.9 (1.01)	1.6 (0.15)	36 7/16" (926)	13.6 (1.26)
AP42V	2.0 (0.17)	43 3/8" (1102)	6 1/2" (165)	13.1 (1.22)	2.0 (0.18)	36 7/16" (926)	16.0 (1.49)
A212	0.9 (0.08)	19 1/2" (495)	6 1/2" (165)	5.2 (0.48)	1.8 (0.16)	60 5/16" (1532)	8.0 (0.74)
A213	0.9 (0.08)	19 1/2" (495)	6 1/2" (165)	7.8 (0.73)	2.6 (0.25)	60 5/16" (1532)	12.0 (1.12)
A312	1.4 (0.13)	31 5/16" (795)	6 1/2" (165)	8.6 (0.80)	2.8 (0.26)	60 5/16" (1532)	12.0 (1.12)
A313	1.4 (0.13)	31 5/16" (795)	6 1/2" (165)	12.9 (1.20)	4.2 (0.39)	60 5/16" (1532)	18.0 (1.67)
PA3050**	1.4 (0.13)	31 5/16" (795)	6 1/2" (165)	4.3 (0.40)	1.4 (0.13)	60 5/16" (1532)	6.0 (0.56)
PA3060**	1.4 (0.13)	31 5/16" (795)	6 1/2" (165)	4.3 (0.40)	1.4 (0.13)	60 5/16" (1532)	6.0 (0.56)
PA3550**	1.6 (0.15)	36 3/16" (919)	6 1/2" (165)	4.9 (0.46)	1.6 (0.15)	60 5/16" (1532)	6.8 (0.63)
PA3560**	1.6 (0.15)	36 3/16" (919)	6 1/2" (165)	4.9 (0.46)	1.6 (0.15)	60 5/16" (1532)	6.8 (0.63)
PA4060**	2.0 (0.18)	43 3/8" (1102)	6 1/2" (165)	5.9 (0.55)	2.0 (0.18)	60 5/16" (1532)	8.0 (0.74)
AXW312	1.4 (0.13)	31 1/3" (795)	6 1/2" (165)	13.6 (1.26)	2.8 (0.26)	48 1/2" (1232)	18.0 (1.67)

• Top of Subfloor to Top of Inside Sill Stop is calculated based upon a structural header height of 6'-10 1/2" (2096).
 * Dimensions in parentheses are in millimeters or square meters.
 * Clear opening area of 5.8 sq. ft. or 0.54 m² and clear opening height of 26 1/2" (673) can be obtained by detaching operator from sash.
 ** Dimensions and calculations are for bottom venting sash.

Casement & Awning Windows

400 SERIES WINDOWS WITH TRIPLE-PANE GLASS



Area Specifications for Picture Windows With Triple-Pane Glass

Window Number	Glass Area Sq. Ft./ (m ²)	Overall Window Area Sq. Ft./ (m ²)
P3030	6.8 (0.63)	9.0 (0.84)
P3035	7.8 (0.73)	10.2 (0.95)
P3040	9.4 (0.87)	12.0 (1.12)
P3045	10.4 (0.97)	13.2 (1.23)
P3050	12.0 (1.12)	14.9 (1.38)
P3055	13.0 (1.21)	16.2 (1.51)
P3060	14.6 (1.36)	17.9 (1.66)
P3530	7.8 (0.73)	10.2 (0.95)
P3535	9.0 (0.84)	11.6 (1.08)
P3540	10.8 (1.00)	13.6 (1.26)
P3545	12.1 (1.12)	15.0 (1.39)
P3550	13.8 (1.28)	17.0 (1.58)
P3555	15.1 (1.40)	18.4 (1.71)
P3560	16.8 (1.56)	20.4 (1.90)
P4030	9.4 (0.87)	12.0 (1.12)
P4035	10.8 (1.00)	13.6 (1.26)
P4040	13.0 (1.21)	16.0 (1.49)
P4045	14.5 (1.35)	17.6 (1.64)
P4050	16.6 (1.54)	20.0 (1.86)
P4055	18.1 (1.68)	21.6 (2.01)
P4060	20.2 (1.88)	24.0 (2.23)
P4530	10.4 (0.97)	13.2 (1.23)
P4535	12.1 (1.12)	15.0 (1.39)
P4540	14.5 (1.35)	17.6 (1.64)
P4545	16.1 (1.50)	19.4 (1.80)
P4550	18.4 (1.71)	22.0 (2.04)
P4555	20.1 (1.87)	23.8 (2.21)
P4560	22.4 (2.08)	26.4 (2.45)
P5030	12.0 (1.12)	14.9 (1.38)
P5035	13.8 (1.28)	17.0 (1.58)
P5040	16.6 (1.54)	20.0 (1.86)
P5045	18.4 (1.71)	22.0 (2.04)
P5050	21.1 (1.96)	24.9 (2.31)
P5055	23.0 (2.14)	26.9 (2.50)
P5060	25.7 (2.39)	29.9 (2.78)
P5530	13.0 (1.21)	16.2 (1.51)
P5535	15.1 (1.40)	18.4 (1.71)
P5540	18.1 (1.68)	21.6 (2.01)
P5545	20.1 (1.87)	23.8 (2.21)
P5550	23.0 (2.14)	26.9 (2.50)
P6030	14.6 (1.36)	17.9 (1.66)
P6035	16.8 (1.56)	20.4 (1.90)
P6040	20.2 (1.88)	24.0 (2.23)
P6045	22.4 (2.08)	26.4 (2.45)
P6050	25.7 (2.39)	29.9 (2.78)

• Dimensions in parentheses are in square meters.

Area Specifications for Transom Windows With Triple-Pane Glass

Window Number	Glass Area Sq. Ft./ (m ²)	Overall Window Area Sq. Ft./ (m ²)
CTR1510	0.7 (0.07)	1.4 (0.13)
CTR1810	0.8 (0.07)	1.7 (0.16)
CTR21810	1.7 (0.16)	3.4 (0.32)
CTR31810	2.6 (0.24)	5.1 (0.47)
CTR2010	1.0 (0.09)	2.0 (0.19)
CTR22010	2.1 (0.19)	4.0 (0.37)
CTR32010	3.1 (0.29)	6.0 (0.56)
CTR2410	1.2 (0.11)	2.4 (0.22)
CTR22410	2.5 (0.24)	4.7 (0.44)
CTR32410	3.8 (0.35)	7.1 (0.66)
CTR2810	1.4 (0.13)	2.6 (0.24)
CTR22810	2.9 (0.27)	5.2 (0.49)
CTR3010	1.6 (0.15)	3.0 (0.28)
CTR23010	3.3 (0.31)	6.0 (0.55)
CTR5110	2.8 (0.26)	5.1 (0.47)
CTR2910	1.5 (0.14)	2.8 (0.26)
CTR3410	1.8 (0.17)	3.4 (0.32)
CTR4010	2.2 (0.20)	4.0 (0.37)
CTR4810	2.6 (0.24)	4.7 (0.44)
CTR5210	2.9 (0.27)	5.2 (0.48)
CTR51110	3.4 (0.32)	6.0 (0.56)
CTR6010	3.4 (0.32)	6.0 (0.56)
CTR7010	4.0 (0.37)	7.1 (0.66)
PTR3010	1.6 (0.15)	3.0 (0.28)
PTR3510	1.8 (0.17)	3.4 (0.32)
PTR4010	2.2 (0.20)	4.0 (0.37)
PTR4510	2.4 (0.22)	4.4 (0.41)
PTR5010	2.8 (0.26)	5.0 (0.47)
PTR5510	3.0 (0.28)	5.4 (0.50)
PTR6010	3.4 (0.32)	6.0 (0.56)

• Dimensions in parentheses are in square meters.

Custom Sizes and Specification Formulas



Available in 1/8" (3) increments between minimum and maximum widths and heights. Windows can also be custom sized to match standard sizes ending in a 1/16" (1.5) of an inch. Some restrictions apply; contact your Andersen supplier. For minimum rough opening dimensions for joined windows, see specific joining instruction guides. Measurement guide for custom-size windows can be found at andersenwindows.com/measure. Available with either traditional or contemporary trim stops.

Casement Windows With Triple-Pane Glass (stationary and venting)

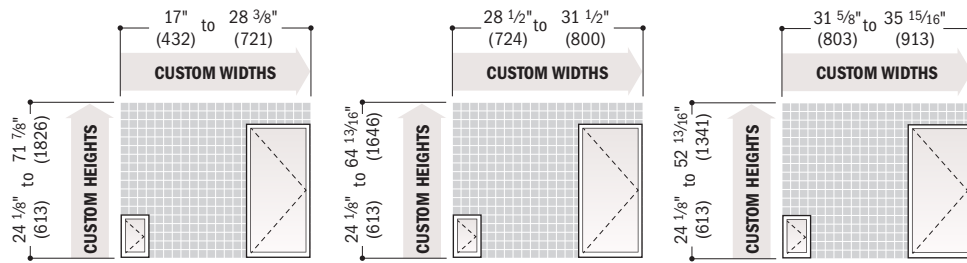

	Clear Opening	Min. R.O.
	<p>Width = window width - 5.81" (148)</p> <p>= (window width - 9.66" (245)) x 1.07</p> <p>= window width - 9.70" (246)</p> <p>Height = window height - 4.43" (113)</p> <p>= window height - 4.85" (123)</p>	<p>Width = window width + 1/2" (13)</p> <p>Height = window height + 1/2" (13)</p>
	<p>Width = window width - 5.81" (148)</p> <p>= window width - 6.10" (155)</p> <p>Height = window height - 4.43" (113)</p> <p>= window height - 4.85" (123)</p>	<p>Width = window width - 4.40" (112)</p> <p>Height = window height - 4.95" (126)</p>

continued on next page

• **Clear Opening** formulas provide dimensions for determining area available for egress. **Vent Opening** formulas provide dimensions for determining area available for passage of air. **Min. R.O.** (minimum rough opening) formulas provide minimum rough opening width and height dimensions. **Unobst. Gls.** (unobstructed glass) formulas provide dimensions for determining area available for passage of light.
 • Refer to andersenwindows.com/measure for detailed instructions on how to properly measure for custom-size windows.
 • Dimensions in parentheses are in millimeters.

Custom Sizes and Specification Formulas (continued)

Awning Windows With Triple-Pane Glass (stationary and venting)

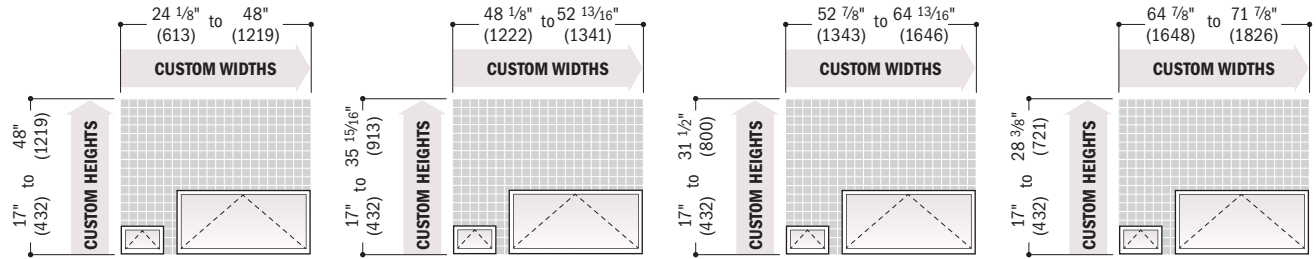

	Clear Opening	Width = window width - 4.53" (115) Depth = 6.38" (162) = 6.44" (164) = 6.50" (165) Height ≥ 17" (432) and < 20 1/2" (521) Height ≥ 20 1/2" (521) and < 24 3/8" (613) All other window heights	Min. R.O.	Width = window width + 1/2" (13) Height = window height + 1/2" (13)
	Vent Opening	Width = window width - 4.53" (115) Depth = 6.38" (162) = 6.44" (164) = 6.50" (165) Height ≥ 17" (432) and < 20 1/2" (521) Height ≥ 20 1/2" (521) and < 24 3/8" (613) All other window heights	Unobst. Gls.	Width = window width - 4.81" (122) Height = window height - 4.51" (115)

Casement/Awning Picture and Transom Windows With Triple-Pane Glass

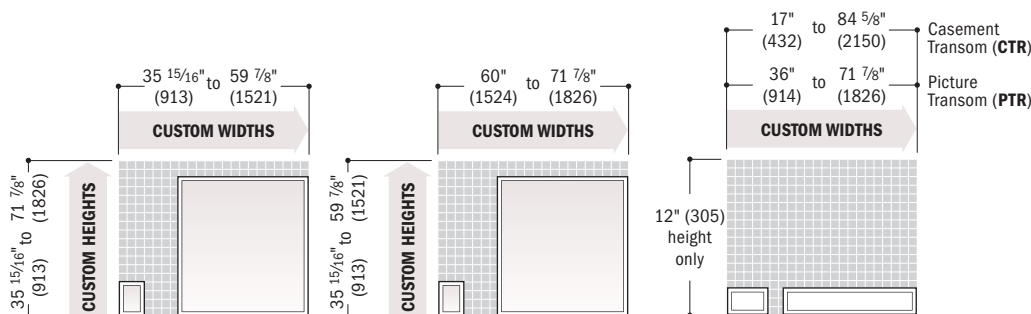

Min. R.O.	Width = window width - 1/2" (13) Height = window height - 1/2" (13)
Unobst. Gls.	Width = window width - 4.80" (122) Height = window height - 4.80" (122)

• **Clear Opening** formulas provide dimensions for determining area available for egress. **Vent Opening** formulas provide dimensions for determining area available for passage of air. **Min. R.O.** (minimum rough opening) formulas provide minimum rough opening width and height dimensions. **Unobst. Gls.** (unobstructed glass) formulas provide dimensions for determining area available for passage of light.
• Refer to andersenwindows.com/measure for detailed instructions on how to properly measure for custom-size windows.
• Dimensions in parentheses are in millimeters.

Grille Options for Casement & Awning Windows With Triple-Pane Glass

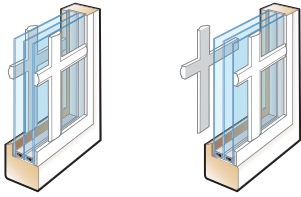

Simulated Divided Light

Simulated divided light (SDL) grilles are permanently applied to the exterior and interior of the window, without a spacer between the glass and are available in 3/4" (19) or 7/8" (22) widths. Interior grilles are available in natural wood or prefinished white and can be ordered permanently applied or removable for easier cleaning.

Casement & Awning Window Grille Profiles

Exterior grilles on casement and awning windows with triple-pane glass have a lower chamfer.

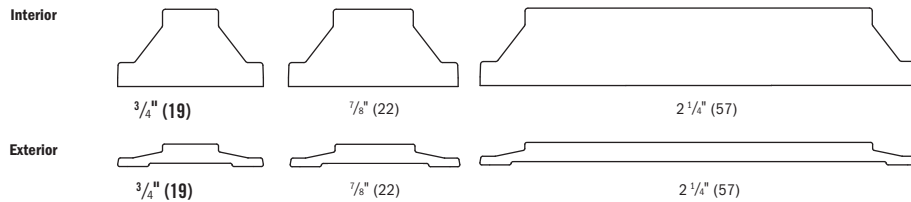

Casement/Awning Picture & Transom Window Grille Profiles

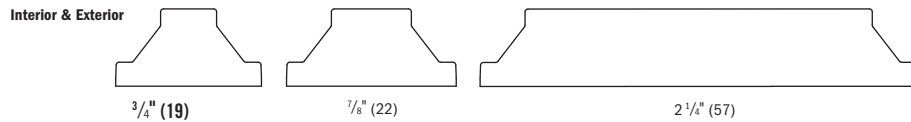

Finelight™ Grille-Between-the-Glass

Andersen® Finelight grilles-between-the-glass are installed between the glass panes and feature a contoured 3/4" (19) profile.

Grille Patterns

	Prairie A	Specified Equal Light with Simulated Meeting Rail	Colonial	Modified Colonial	Modified Colonial with Simulated Meeting Rail	Tall Fractional	Tall Fractional with Simulated Meeting Rail	Short Fractional	Short Fractional with Simulated Meeting Rail
Casement									
Awning									
Picture									
Transom									

Grilles are available with a traditional or contemporary grille bar profile.

Number of lights and overall pattern varies with window size. Patterns may not be available in all configurations or sizes. Specified equal light are also available.

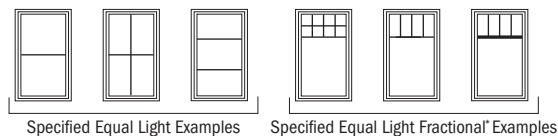

*Bottom horizontal bar located at center and custom dimensions.

Interior Trim Options

Extension jamb and drywall return bead applications shown.

Traditional trim stops shown, contemporary trim stops are also available.

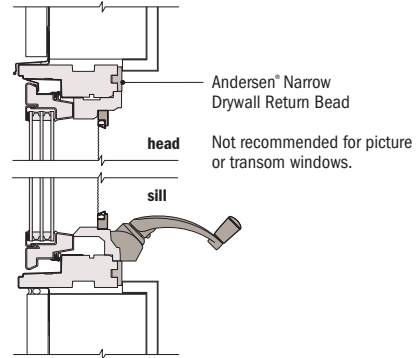
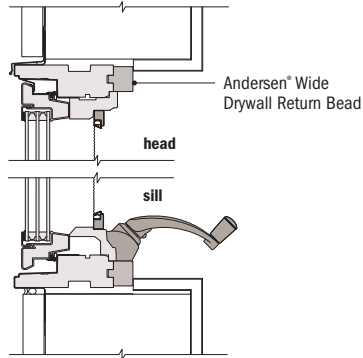
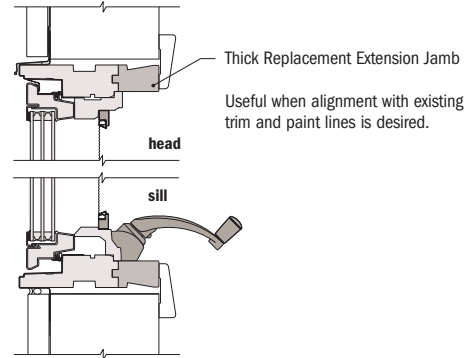
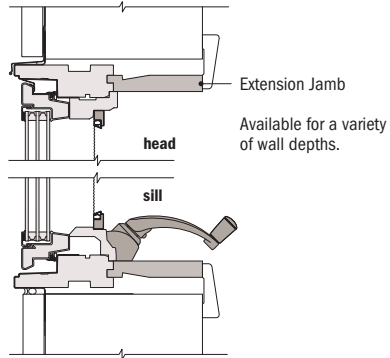

• Light-colored areas are parts included with window. Dark-colored areas are additional Andersen® parts required to complete window assembly as shown.
 • Details are for illustration only and are not intended to represent product installation methods or materials. Refer to product installation guides at andersenwindows.com.

400 SERIES WINDOWS WITH TRIPLE-PANE GLASS

Details for Casement Windows With Triple-Pane Glass – Traditional Trim Stops

Scale 1 1/2" (38) = 1'-0" (305) – 1:8

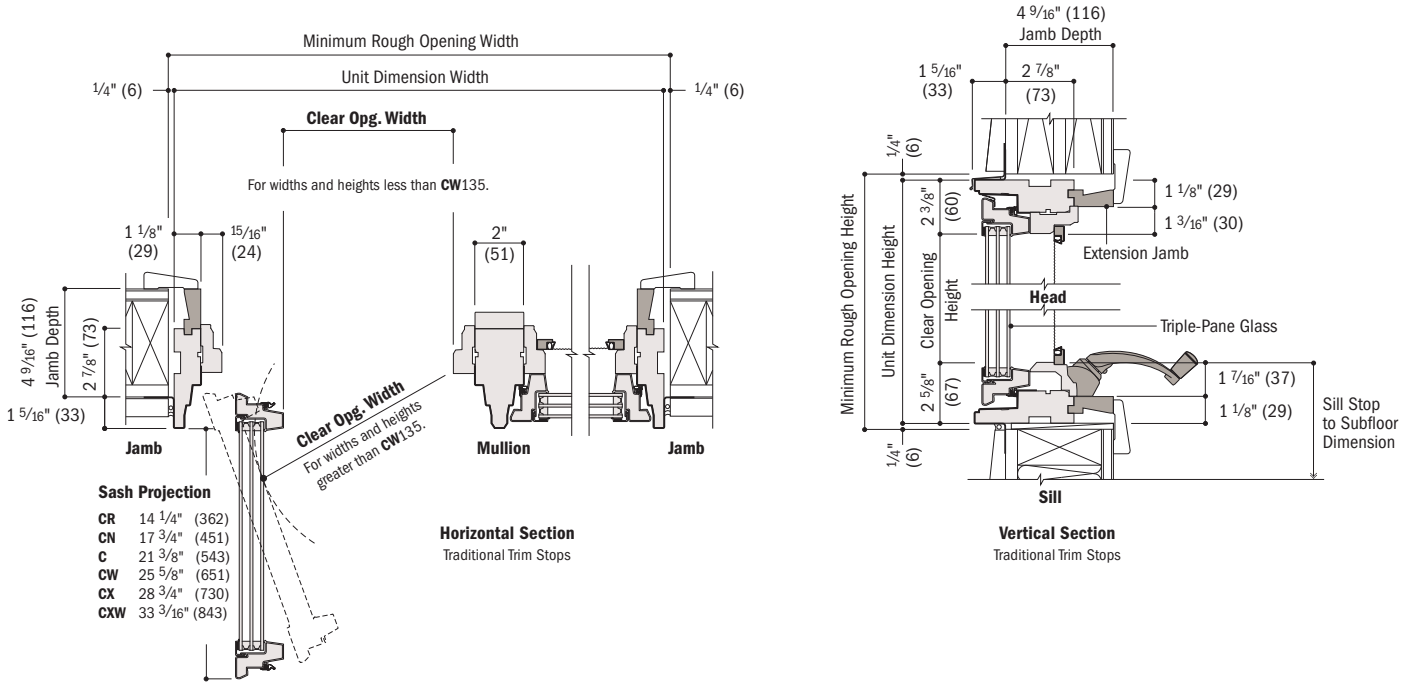

Casement & Awning Windows

Details for Casement Windows With Triple-Pane Glass – Contemporary Trim Stops

Scale 1 1/2" (38) = 1'-0" (305) – 1:8

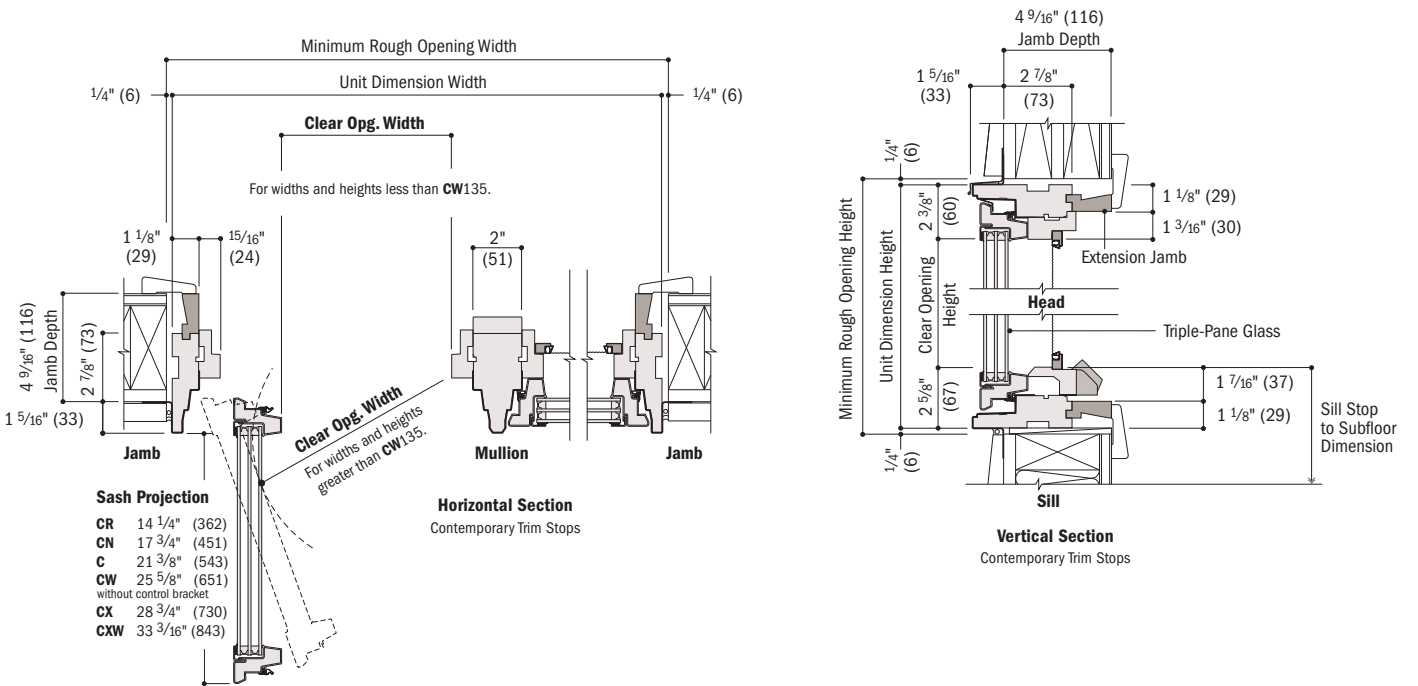

- 4 9/16" (116) overall jamb depth and 2 7/8" (73) base jamb depth measurement is from back side of installation flange.
- Light-colored areas are parts included with window. Dark-colored areas are additional Andersen® parts required to complete window assembly as shown.
- **Minimum rough openings may need to be increased to allow for use of building wraps, flashing, sill panning, brackets, fasteners or other items.**
- Details are for illustration only and are not intended to represent product installation methods or materials. Refer to product installation guides at andersenwindows.com.
- Dimensions in parentheses are in millimeters.

400 SERIES WINDOWS WITH TRIPLE-PANE GLASS



Details for Awning Windows With Triple-Pane Glass – Traditional Trim Stops

Scale 1 1/2" (38) = 1'-0" (305) – 1:8

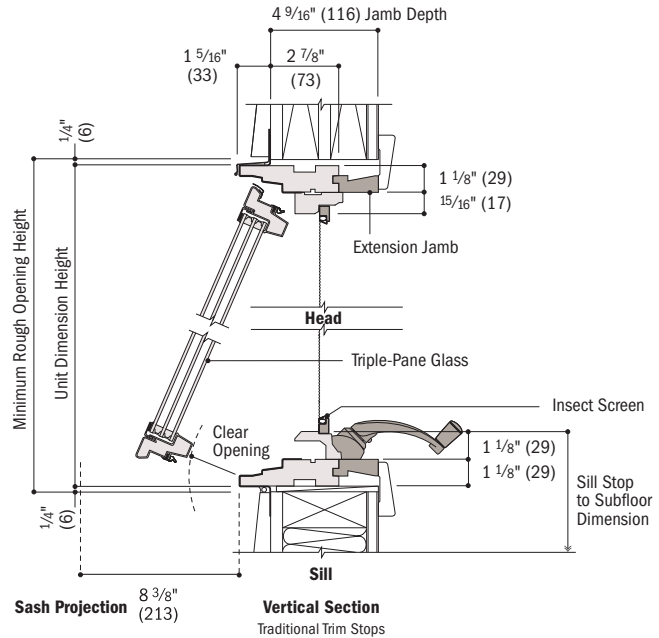
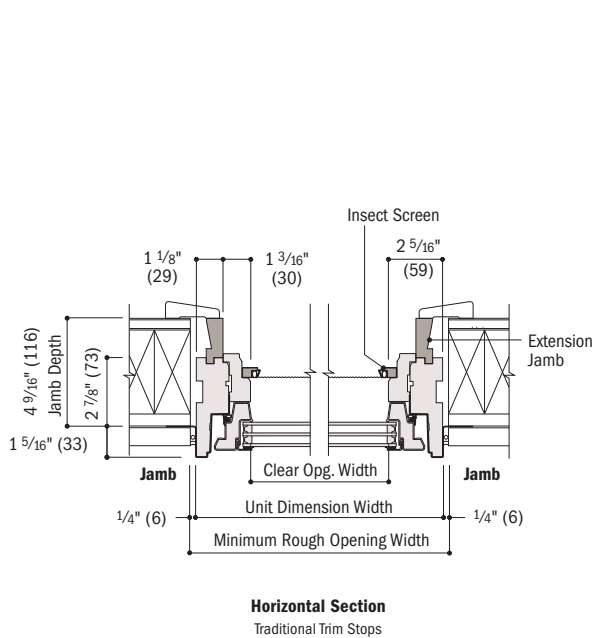

Casement & Awning Windows

Details for Awning Windows With Triple-Pane Glass – Contemporary Trim Stops

Scale 1 1/2" (38) = 1'-0" (305) – 1:8

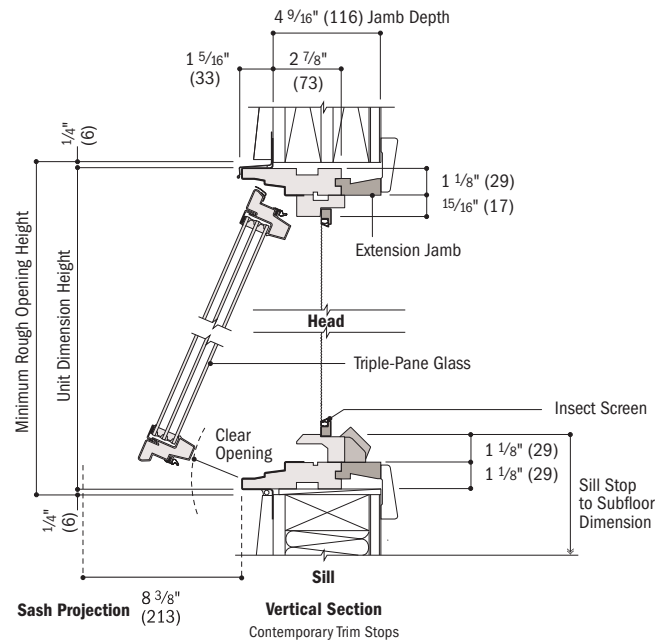
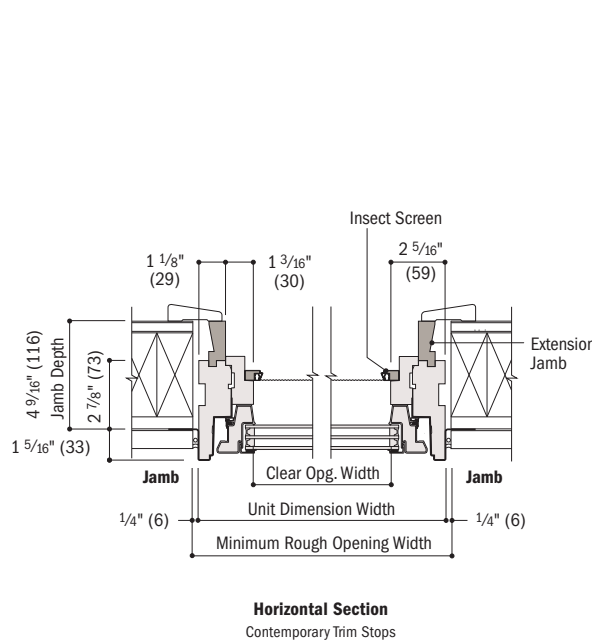

- 4 9/16" (116) overall jamb depth and 2 7/8" (73) base jamb depth measurement is from back side of installation flange.
- Light-colored areas are parts included with window. Dark-colored areas are additional Andersen® parts required to complete window assembly as shown.
- **Minimum rough openings may need to be increased to allow for use of building wraps, flashing, sill panning, brackets, fasteners or other items.**
- Details are for illustration only and are not intended to represent product installation methods or materials. Refer to product installation guides at andersenwindows.com.
- Dimensions in parentheses are in millimeters.

Details for Picture and Transom Windows With Triple-Pane Glass – Traditional Trim Stops

Scale 1 1/2" (38) = 1'-0" (305) – 1:8

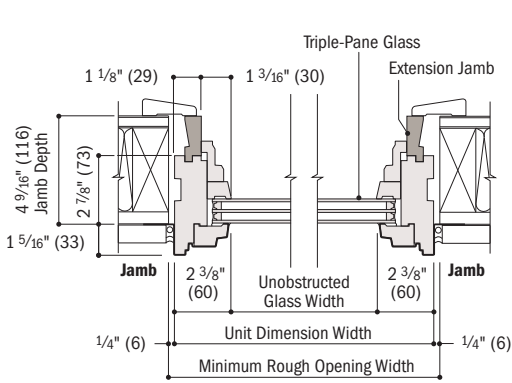

Horizontal Section
Traditional Trim Stops

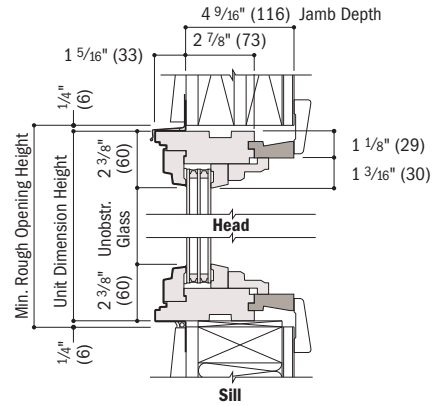

Vertical Section
Traditional Trim Stops

Details for Picture and Transom Windows With Triple-Pane Glass – Contemporary Trim Stops

Scale 1 1/2" (38) = 1'-0" (305) – 1:8

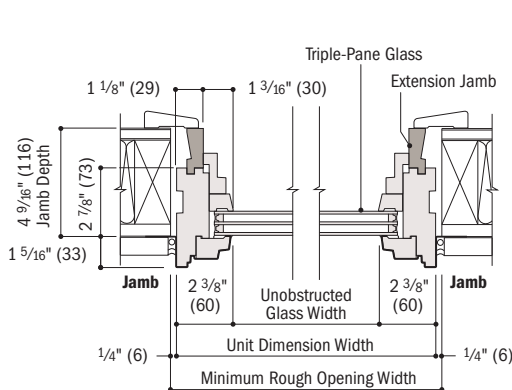

Horizontal Section
Contemporary Trim Stops

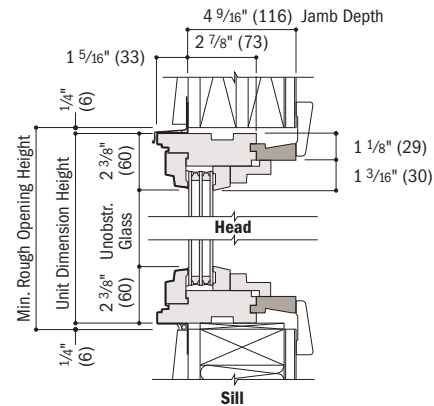

Vertical Section
Contemporary Trim Stops

- 4 9/16" (116) overall jamb depth and 2 7/8" (73) base jamb depth measurement is from back side of installation flange.
- Light-colored areas are parts included with window. Dark-colored areas are additional Andersen® parts required to complete window assembly as shown.
- **Minimum rough openings may need to be increased to allow for use of building wraps, flashing, sill panning, brackets, fasteners or other items.**
- Details are for illustration only and are not intended to represent product installation methods or materials. Refer to product installation guides at andersenwindows.com.
- Dimensions in parentheses are in millimeters.

400 SERIES WINDOWS WITH TRIPLE-PANE GLASS



Horizontal (stack) Joining Detail

Scale 1 1/2" (38) = 1'-0" (305) – 1:8

Overall Window Dimension Height

Sum of individual window heights plus 1/8" (3) per join.

Overall Rough Opening Height

Overall window dimension height plus 1/2" (13).

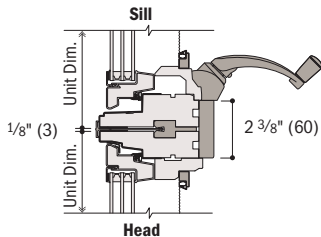

Vertical Section
Casement Over Awning

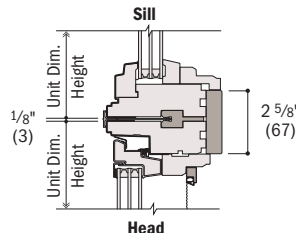

Vertical Section
Picture Over Casement

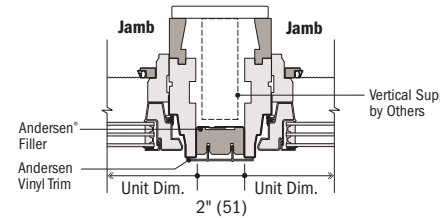

Horizontal Section
Casement and Casement

Vertical (ribbon) Joining Detail

Scale 1 1/2" (38) = 1'-0" (305) – 1:8

Overall Window Dimension Width

Sum of individual window widths plus 1/8" (3) per join.

Overall Rough Opening Width

Overall window dimension width plus 1/2" (13).

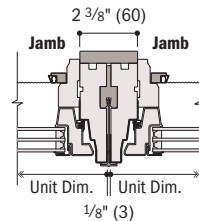

Horizontal Section
Casement to Casement

Joined combinations are limited by weight restrictions, contact your Andersen supplier for more information.

For more information on joining, refer to pages 42-49.

- 4 9/16" (116) overall jamb depth and 2 1/8" (73) base jamb depth measurement is from back side of installation flange.
- Light-colored areas are parts included with window. Dark-colored areas are additional Andersen® parts required to complete window assembly as shown.
- **Minimum rough openings may need to be increased to allow for use of building wraps, flashing, sill panning, brackets, fasteners or other items.**
- Details are for illustration only and are not intended to represent product installation methods or materials. Refer to product installation guides at andersenwindows.com.
- Structural performance of any combination is only as high as the lowest structural performance of any individual product or join in the combination.
- Consult with an architect or structural engineer regarding minimum requirements for structural support members between adjacent rough openings.
- Traditional trim stops shown in joining details. Details also apply to products with contemporary trim stops.
- Dimensions in parentheses are in millimeters.

400 SERIES WINDOWS WITH TRIPLE-PANE GLASS



Table of Sizes for Tilt-Wash Double-Hung Windows With Triple-Pane Glass

Scale 1/8" (3) = 1'-0" (305) – 1:96

Window Dimension	1'-9 5/8" (549)	2'-1 5/8" (651)	2'-5 5/8" (752)	2'-7 5/8" (803)	2'-9 5/8" (854)	2'-11 5/8" (905)	3'-1 5/8" (956)	3'-5 5/8" (1057)	3'-9 5/8" (1159)
Minimum Rough Opening	1'-10 1/8" (562)	2'-2 1/8" (664)	2'-6 1/8" (765)	2'-8 1/8" (816)	2'-10 1/8" (867)	3'-0 1/8" (917)	3'-2 1/8" (968)	3'-6 1/8" (1070)	3'-10 1/8" (1172)
Unobstructed Glass (lower sash only)	15" (381)	19" (483)	23" (584)	25" (635)	27" (686)	29" (737)	31" (787)	35" (889)	39" (991)

CUSTOM WIDTHS – 21 5/8" to 45 5/8"

Window Dimension	1'-9 5/8" (549)	2'-1 5/8" (651)	2'-5 5/8" (752)	2'-7 5/8" (803)	2'-9 5/8" (854)	2'-11 5/8" (905)	3'-1 5/8" (956)	3'-5 5/8" (1057)	3'-9 5/8" (1159)
3'-0 7/8" (937)	TW18210	TW20210	TW24210	TW26210	TW28210	TW210210	TW30210	TW34210	TW38210
3'-4 7/8" (1038)	TW1832	TW2032	TW2432	TW2632	TW2832	TW21032	TW3032	TW3432	TW3832
3'-8 7/8" (1140)	TW1836	TW2036	TW2436	TW2636	TW2836	TW21036	TW3036	TW3436	TW3836
4'-0 7/8" (1241)	TW18310	TW20310	TW24310	TW26310	TW28310	TW210310	TW30310	TW34310	TW38310
4'-4 7/8" (1343)	TW1842	TW2042	TW2442	TW2642	TW2842	TW21042	TW3042	TW3442	TW3842
4'-8 7/8" (1445)	TW1846	TW2046	TW2446	TW2646	TW2846	TW21046	TW3046 ^o	TW3446 ^o	TW3846 ^o
5'-0 7/8" (1546)	TW18410	TW20410	TW24410	TW26410	TW28410	TW210410 ^o	TW30410 ^o	TW34410 ^o	TW38410 ^o
5'-4 7/8" (1648)	TW1852	TW2052	TW2452	TW2652	TW2852 ^o	TW21052 ^o	TW3052 ^o	TW3452 ^o	TW3852 ^o
5'-8 7/8" (1749)	TW1856	TW2056	TW2456	TW2656 ^o	TW2856 ^o	TW21056 ^o	TW3056 ^o	TW3456 ^o	TW3856 ^o
6'-0 7/8" (1851)	TW18510	TW20510	TW24510 ^o	TW26510 ^o	TW28510 ^o	TW210510 ^o	TW30510 ^o	TW34510 ^o	TW38510 ^o
6'-4 7/8" (1953)	TW1862	TW2062	TW2462 ^o	TW2662 ^o	TW2862 ^o	TW21062 ^o	TW3062 ^o	TW3462 ^o	TW3862 ^o

CUSTOM HEIGHTS – 36 7/8" to 92 7/8"



Custom-size windows are available in 1/8" (3) increments. See page 31.

Grille information shown on page 32. Details shown on pages 33-34.

Tilt-Wash Double-Hung Windows

• Window Dimension always refers to outside frame-to-frame dimension.
 • Minimum Rough Opening dimensions may need to be increased to allow for use of building wraps, flashing, sill panning, brackets, fasteners or other items.
 • Dimensions in parentheses are in millimeters.
 ◊Meets or exceeds clear opening area of 5.7 sq. ft. or 0.53 m², clear opening width of 20" (508) and clear opening height of 24" (610).

continued on next page

400 SERIES WINDOWS WITH TRIPLE-PANE GLASS



Table of Sizes for Tilt-Wash Double-Hung Windows With Triple-Pane Glass *(continued)*

Scale 1/8" (3) = 1'-0" (305) – 1:96

Window Dimension	1'-9 5/8" (549)	2'-1 5/8" (651)	2'-5 5/8" (752)	2'-7 5/8" (803)	2'-9 5/8" (854)	2'-11 5/8" (905)	3'-1 5/8" (956)	3'-5 5/8" (1057)	3'-9 5/8" (1159)
Minimum Rough Opening	1'-10 1/8" (562)	2'-2 1/8" (664)	2'-6 1/8" (765)	2'-8 1/8" (816)	2'-10 1/8" (867)	3'-0 1/8" (917)	3'-2 1/8" (968)	3'-6 1/8" (1070)	3'-10 1/8" (1172)
Unobstructed Glass (lower sash only)	15" (381)	19" (483)	23" (584)	25" (635)	27" (686)	29" (737)	31" (787)	35" (889)	39" (991)



		CUSTOM WIDTHS – 21 5/8" to 45 5/8"								
7'-4 7/8" (2257) 7'-4 7/8" (2257) 39 15/16" (1014)	CUSTOM HEIGHTS – 36 7/8" to 92 7/8"									
		TW1872	TW2072 [◊]	TW2472 [◊]	TW2672 [◊]	TW2872 [◊]	TW21072 [◊]	TW3072 [◊]	TW3472 [◊]	TW3872 [◊]
7'-8 7/8" (2359) 7'-8 7/8" (2359) 41 15/16" (1065)										
		TW1876	TW2076 [◊]	TW2476 [◊]	TW2676 [◊]	TW2876 [◊]	TW21076 [◊]	TW3076 [◊]	TW3476 [◊]	TW3876 [◊]

Custom-size windows are available in 1/8" (3) increments. See page 31.

Equal sash windows greater than 6'-4 7/8" (1953) in height have interior and exterior brackets. Interior brackets, located on both sides of the meeting rail, must be flipped up for proper product performance.

- Window Dimension always refers to outside frame-to-frame dimension.
- **Minimum Rough Opening dimensions may need to be increased to allow for use of building wraps, flashing, sill panning, brackets, fasteners or other items.**
- Dimensions in parentheses are in millimeters.
- ◊ Meets or exceeds clear opening area of 5.7 sq. ft. or 0.53 m², clear opening width of 20" (508) and clear opening height of 24" (610).

Grille information shown on page 32. Details shown on pages 33-34.

Tilt-Wash Double-Hung Windows

400 SERIES WINDOWS WITH TRIPLE-PANE GLASS



Table of Sizes for Tilt-Wash Double-Hung Windows With Triple-Pane Glass – Cottage Sash

Scale 1/8" (3) = 1'-0" (305) – 1:96

Window Dimension	1'-9 5/8"	2'-1 5/8"	2'-5 5/8"	2'-7 5/8"	2'-9 5/8"	2'-11 5/8"	3'-1 5/8"	3'-5 5/8"	3'-9 5/8"
	(549)	(651)	(752)	(803)	(854)	(905)	(956)	(1057)	(1159)
Minimum Rough Opening	1'-10 1/8"	2'-2 1/8"	2'-6 1/8"	2'-8 1/8"	2'-10 1/8"	3'-0 1/8"	3'-2 1/8"	3'-6 1/8"	3'-10 1/8"
	(562)	(664)	(765)	(816)	(867)	(917)	(968)	(1070)	(1172)
Unobstructed Glass	15"	19"	23"	25"	27"	29"	31"	35"	39"
	(381)	(483)	(584)	(635)	(686)	(737)	(787)	(889)	(991)



CUSTOM WIDTHS – 1'-9 5/8" to 3'-9 5/8"

CUSTOM HEIGHTS – 4'-0 7/8" to 6'-4 7/8"	CUSTOM WIDTHS – 1'-9 5/8" to 3'-9 5/8"								
	1'-9 5/8"	2'-1 5/8"	2'-5 5/8"	2'-7 5/8"	2'-9 5/8"	2'-11 5/8"	3'-1 5/8"	3'-5 5/8"	3'-9 5/8"
4'-0 7/8" (1241)	TW18310	TW20310	TW24310	TW26310	TW28310	TW210310	TW30310	TW34310	TW38310
4'-4 7/8" (1343)	TW1842	TW2042	TW2442	TW2642	TW2842	TW21042	TW3042	TW3442	TW3842
4'-8 7/8" (1445)	TW1846	TW2046	TW2446	TW2646	TW2846	TW21046	TW3046	TW3446	TW3846
5'-0 7/8" (1546)	TW18410	TW20410	TW24410	TW26410	TW28410	TW210410	TW30410	TW34410	TW38410
5'-4 7/8" (1648)	TW1852	TW2052	TW2452	TW2652	TW2852	TW21052	TW3052	TW3452	TW3852
5'-8 7/8" (1749)	TW1856	TW2056	TW2456	TW2656	TW2856	TW21056	TW3056 ^o	TW3456 ^o	TW3856 ^o
6'-0 7/8" (1851)	TW18510	TW20510	TW24510	TW26510	TW28510	TW210510	TW30510	TW34510	TW38510
6'-4 7/8" (1953)	TW1862	TW2062	TW2462	TW2662	TW2862	TW21062 ^o	TW3062 ^o	TW3462 ^o	TW3862 ^o

Custom-size windows are available in 1/8" (3) increments. See page 31.

Cottage sash windows greater than 5'-8 7/8" (1749) in height have interior and exterior brackets. Interior brackets, located on both sides of the meeting rail, must be flipped up for proper product performance.

Grille information shown on page 32. Details shown on pages 33-34.

Tilt-Wash Double-Hung Windows

* Window Dimension always refers to outside frame-to-frame dimension.
 • **Minimum Rough Opening dimensions may need to be increased to allow for use of building wraps, flashing, sill panning, brackets, fasteners or other items.**
 • Dimensions in parentheses are in millimeters.
^oMeets or exceeds clear opening area of 5.7 sq. ft. or 0.53 m², clear opening width of 20" (508) and clear opening height of 24" (610).

400 SERIES WINDOWS WITH TRIPLE-PANE GLASS



Table of Sizes for Tilt-Wash Double-Hung Windows With Triple-Pane Glass – Reverse Cottage Sash

Scale 1/8" (3) = 1'-0" (305) – 1:96

Window Dimension	1'-9 5/8" (549)	2'-1 5/8" (651)	2'-5 5/8" (752)	2'-7 5/8" (803)	2'-9 5/8" (854)	2'-11 5/8" (905)	3'-1 5/8" (956)	3'-5 5/8" (1057)	3'-9 5/8" (1159)
Minimum Rough Opening	1'-10 1/8" (562)	2'-2 1/8" (664)	2'-6 1/8" (765)	2'-8 1/8" (816)	2'-10 1/8" (867)	3'-0 1/8" (917)	3'-2 1/8" (968)	3'-6 1/8" (1070)	3'-10 1/8" (1172)
Unobstructed Glass	15" (381)	19" (483)	23" (584)	25" (635)	27" (686)	29" (737)	31" (787)	35" (889)	39" (991)



		CUSTOM WIDTHS – 1'-9 5/8" to 3'-9 5/8"								
CUSTOM HEIGHTS – 4'-0 7/8" to 6'-4 7/8"	4'-0 7/8" (1241)									
	4'-4 7/8" (1343)									
	4'-8 7/8" (1445)									
	5'-0 7/8" (1546)									
	5'-4 7/8" (1648)									
	5'-8 7/8" (1749)									
	6'-0 7/8" (1851)									
	6'-4 7/8" (1953)									

Custom-size windows are available in 1/8" (3) increments. See page 31.

Reverse cottage sash windows greater than 5'-8 7/8" (1749) in height have interior and exterior brackets. Interior brackets, located on both sides of the meeting rail, must be flipped up for proper product performance.

Grille information shown on page 32. Details shown on pages 33-34.

Tilt-Wash Double-Hung Windows

* Window Dimension always refers to outside frame-to-frame dimension.
 • Minimum Rough Opening dimensions may need to be increased to allow for use of building wraps, flashing, sill panning, brackets, fasteners or other items.
 • Dimensions in parentheses are in millimeters.
 ° Meets or exceeds clear opening area of 5.7 sq. ft. or 0.53 m², clear opening width of 20" (508) and clear opening height of 24" (610).

400 SERIES WINDOWS WITH TRIPLE-PANE GLASS



Table of Sizes for Tilt-Wash Transom Windows With Triple-Pane Glass

Scale 1/8" = 1'-0" (1:96)

Window Dimension	1'-9 5/8" (549)	2'-1 5/8" (651)	2'-5 5/8" (752)	2'-7 5/8" (803)	2'-9 5/8" (854)	2'-11 5/8" (905)	3'-1 5/8" (956)	3'-5 5/8" (1057)	3'-9 5/8" (1159)	3'-11 5/16" (1202)	4'-3 5/16" (1303)
Minimum Rough Opening	1'-10 1/8" (562)	2'-2 1/8" (664)	2'-6 1/8" (765)	2'-8 1/8" (816)	2'-10 1/8" (867)	3'-0 1/8" (917)	3'-2 1/8" (968)	3'-6 1/8" (1070)	3'-10 1/8" (1172)	3'-11 7/8" (1215)	4'-3 7/8" (1318)
Unobstructed Glass	15" (380)	19" (482)	23" (583)	25" (635)	27" (685)	29" (737)	31" (787)	35" (888)	39" (990)	40 11/16" (1033)	44 11/16" (1135)

continued below

CUSTOM WIDTHS AVAILABLE

1'-0" (305)	TWT1810	TWT2010	TWT2410	TWT2610	TWT2810	TWT21010	TWT3010	TWT3410	TWT3810	TWT31010	TWT4210
1'-7 5/16" (491)	TWT1815	TWT2015	TWT2415	TWT2615	TWT2815	TWT21015	TWT3015	TWT3415	TWT3815		
1'-9 5/16" (541)	TWT1817	TWT2017	TWT2417	TWT2617	TWT2817	TWT21017	TWT3017	TWT3417	TWT3817		
1'-9 7/8" (555)											
1'-1 7/8" (657)	TWT18111	TWT20111	TWT24111	TWT26111	TWT28111	TWT210111	TWT30111	TWT34111	TWT38111		
1'-1 5/16" (643)											
2'-1 7/8" (657)											
2'-1 5/16" (643)											
2'-3 5/16" (694)	TWT1821	TWT2021	TWT2421	TWT2621	TWT2821	TWT21021	TWT3021	TWT3421	TWT3821		
2'-3 7/8" (707)											
2'-5 5/16" (745)	TWT1823	TWT2023	TWT2423	TWT2623	TWT2823	TWT21023	TWT3023	TWT3423	TWT3823		
2'-5 7/8" (758)											
2'-9 5/16" (846)	TWT1827	TWT2027	TWT2427	TWT2627	TWT2827	TWT21027	TWT3027	TWT3427	TWT3827		
2'-9 7/8" (860)											
2'-11 1/16" (877)											
3'-3 5/16" (999)	TWT1831	TWT2031	TWT2431	TWT2631	TWT2831	TWT21031	TWT3031	TWT3431	TWT3831		
3'-3 7/8" (1012)											
3'-11 1/16" (829)											

CUSTOM HEIGHTS AVAILABLE



Custom-size windows are available in 1/8" (3) increments. See page 31.

Grille information shown on page 32. Details shown on pages 33-34.

Tilt-Wash Double-Hung Windows

Window Dimension	4'-11 5/16" (1057)	5'-7 5/16" (1710)	6'-3 5/16" (1913)
Minimum Rough Opening	4'-11 7/8" (1070)	5'-7 7/8" (1724)	6'-3 7/8" (1927)
Unobstructed Glass	52 11/16" (905)	60 11/16" (1556)	68 11/16" (1745)

CUSTOM WIDTHS AVAILABLE

1'-0" (305)	TWT41010	TWT5610	TWT6210
1'-0 1/2" (318)			
5 3/8" (136)			

CUSTOM HEIGHTS AVAILABLE

- Window Dimension always refers to outside frame-to-frame dimension.
- Minimum Rough Opening dimensions may need to be increased to allow for use of building wraps, flashing, sill panning, brackets, fasteners or other items.
- Dimensions in parentheses are in millimeters.

400 SERIES WINDOWS WITH TRIPLE-PANE GLASS



Area & Opening Specifications for Tilt-Wash Double-Hung Windows With Triple-Pane Glass

Window Number	Clear Opening Area Sq. Ft./ (m ²)		Clear Opening in Full Open Position		Glass Area Sq. Ft./ (m ²)	Vent Area Sq. Ft./ (m ²)	Top of Subfloor to Top of Inside Sill Stop Inches/ (mm)		Overall Window Area Sq. Ft./ (m ²)
			Width Inches/ (mm)	Height Inches/ (mm)					
TW18210	1.77	(0.16)	17 1/8" (454)	14 1/4" (362)	2.90 (0.27)	1.78 (0.17)	48 1/2" (1231)	5.53 (0.51)	
TW1832	2.02	(0.19)	17 1/8" (454)	16 1/4" (412)	3.32 (0.31)	2.03 (0.19)	44 1/2" (1130)	6.14 (0.57)	
TW1836	2.26	(0.21)	17 1/8" (454)	18 1/4" (463)	3.74 (0.35)	2.28 (0.21)	40 1/2" (1028)	6.74 (0.63)	
TW18310	2.51	(0.23)	17 1/8" (454)	20 1/4" (514)	4.15 (0.39)	2.53 (0.24)	36 1/2" (926)	7.34 (0.68)	
TW1842	2.76	(0.26)	17 1/8" (454)	22 1/4" (565)	4.57 (0.43)	2.78 (0.26)	32 1/2" (825)	7.94 (0.74)	
TW1846	3.07	(0.29)	17 1/8" (454)	24 3/4" (628)	4.98 (0.46)	3.03 (0.28)	28 1/2" (711)	8.54 (0.79)	
TW18410	3.26	(0.30)	17 1/8" (454)	26 1/4" (666)	5.40 (0.50)	3.27 (0.30)	24 1/2" (622)	9.14 (0.85)	
TW1852	3.51	(0.33)	17 1/8" (454)	28 1/4" (717)	5.81 (0.54)	3.52 (0.33)	20 1/2" (520)	9.74 (0.91)	
TW1856	3.75	(0.35)	17 1/8" (454)	30 1/4" (768)	6.23 (0.58)	3.77 (0.35)	16 1/2" (418)	10.34 (0.96)	
TW18510	4.00	(0.37)	17 1/8" (454)	32 1/4" (819)	6.65 (0.62)	4.02 (0.37)	12 1/2" (317)	10.94 (1.02)	
TW1862	4.12	(0.38)	17 1/8" (454)	33 1/4" (843)	7.06 (0.66)	4.24 (0.39)	8 1/2" (203)	11.54 (1.07)	
TW1872	5.00	(0.46)	17 1/8" (454)	40 1/4" (1022)	8.32 (0.77)	5.03 (0.47)	10 1/4" * (260) *	13.35 (1.24)	
TW1876	5.24	(0.49)	17 1/8" (454)	42 1/4" (1073)	8.74 (0.81)	5.27 (0.49)	6 1/4" * (159) *	13.95 (1.30)	
TW20210	2.16	(0.20)	21 1/8" (556)	14 1/4" (362)	3.68 (0.34)	2.18 (0.20)	48 1/2" (1231)	6.56 (0.61)	
TW2032	2.47	(0.23)	21 1/8" (556)	16 1/4" (412)	4.21 (0.39)	2.48 (0.23)	44 1/2" (1130)	7.27 (0.68)	
TW2036	2.77	(0.26)	21 1/8" (556)	18 1/4" (463)	4.73 (0.44)	2.79 (0.26)	40 1/2" (1028)	7.98 (0.74)	
TW20310	3.07	(0.29)	21 1/8" (556)	20 1/4" (514)	5.26 (0.49)	3.09 (0.29)	36 1/2" (926)	8.69 (0.81)	
TW2042	3.38	(0.31)	21 1/8" (556)	22 1/4" (565)	5.79 (0.54)	3.40 (0.32)	32 1/2" (825)	9.41 (0.87)	
TW2046	3.76	(0.35)	21 1/8" (556)	24 3/4" (628)	6.31 (0.59)	3.71 (0.34)	28 1/2" (711)	10.12 (0.94)	
TW20410	3.99	(0.37)	21 1/8" (556)	26 1/4" (666)	6.84 (0.64)	4.00 (0.37)	24 1/2" (622)	10.83 (1.01)	
TW2052	4.29	(0.40)	21 1/8" (556)	28 1/4" (717)	7.37 (0.69)	4.31 (0.40)	20 1/2" (520)	11.54 (1.07)	
TW2056	4.59	(0.43)	21 1/8" (556)	30 1/4" (768)	7.89 (0.73)	4.61 (0.43)	16 1/2" (418)	12.25 (1.14)	
TW20510	4.90	(0.46)	21 1/8" (556)	32 1/4" (819)	8.42 (0.78)	4.92 (0.46)	12 1/2" (317)	12.96 (1.20)	
TW2062	5.04	(0.47)	21 1/8" (556)	33 1/4" (843)	8.95 (0.83)	5.18 (0.48)	8 1/2" (203)	13.68 (1.27)	
TW2072 ◊	6.11	(0.57)	21 1/8" (556)	40 1/4" (1022)	10.54 (0.98)	6.14 (0.57)	10 1/4" * (260) *	15.82 (1.47)	
TW2076 ◊	6.42	(0.60)	21 1/8" (556)	42 1/4" (1073)	11.06 (1.03)	6.45 (0.60)	6 1/4" * (159) *	16.53 (1.54)	
TW24210	2.56	(0.24)	25 1/8" (657)	14 1/4" (362)	4.46 (0.41)	2.58 (0.24)	48 1/2" (1231)	7.58 (0.70)	
TW2432	2.92	(0.27)	25 1/8" (657)	16 1/4" (412)	5.09 (0.47)	2.94 (0.27)	44 1/2" (1130)	8.40 (0.78)	
TW2436	3.28	(0.31)	25 1/8" (657)	18 1/4" (463)	5.73 (0.53)	3.30 (0.31)	40 1/2" (1028)	9.23 (0.86)	
TW24310	3.64	(0.34)	25 1/8" (657)	20 1/4" (514)	6.37 (0.59)	3.66 (0.34)	36 1/2" (926)	10.05 (0.93)	
TW2442	4.00	(0.37)	25 1/8" (657)	22 1/4" (565)	7.01 (0.65)	4.02 (0.37)	32 1/2" (825)	10.87 (1.01)	
TW2446	4.44	(0.41)	25 1/8" (657)	24 3/4" (628)	7.65 (0.71)	4.39 (0.41)	28 1/2" (711)	11.70 (1.09)	
TW24410	4.71	(0.44)	25 1/8" (657)	26 1/4" (666)	8.28 (0.77)	4.74 (0.44)	24 1/2" (622)	12.52 (1.16)	
TW2452	5.07	(0.47)	25 1/8" (657)	28 1/4" (717)	8.92 (0.83)	5.10 (0.47)	20 1/2" (520)	13.34 (1.24)	
TW2456	5.43	(0.51)	25 1/8" (657)	30 1/4" (768)	9.56 (0.89)	5.46 (0.51)	16 1/2" (418)	14.17 (1.32)	
TW24510 ◊	5.79	(0.54)	25 1/8" (657)	32 1/4" (819)	10.20 (0.95)	5.81 (0.54)	12 1/2" (317)	14.99 (1.39)	
TW2462 ◊	5.97	(0.55)	25 1/8" (657)	33 1/4" (843)	10.84 (1.01)	6.13 (0.57)	8 1/2" (203)	15.81 (1.47)	
TW2472 ◊	7.23	(0.67)	25 1/8" (657)	40 1/4" (1022)	12.76 (1.19)	7.26 (0.68)	10 1/4" * (260) *	18.28 (1.70)	
TW2476 ◊	7.59	(0.71)	25 1/8" (657)	42 1/4" (1073)	13.40 (1.25)	7.62 (0.71)	6 1/4" * (159) *	19.11 (1.78)	
TW26210	2.76	(0.26)	27 1/8" (708)	14 1/4" (362)	4.84 (0.45)	2.78 (0.26)	48 1/2" (1231)	8.09 (0.75)	
TW2632	3.14	(0.29)	27 1/8" (708)	16 1/4" (412)	5.54 (0.52)	3.17 (0.30)	44 1/2" (1130)	8.97 (0.83)	
TW2636	3.53	(0.33)	27 1/8" (708)	18 1/4" (463)	6.23 (0.58)	3.55 (0.33)	40 1/2" (1028)	9.85 (0.92)	
TW26310	3.92	(0.36)	27 1/8" (708)	20 1/4" (514)	6.92 (0.64)	3.94 (0.37)	36 1/2" (926)	10.73 (1.00)	
TW2642	4.30	(0.40)	27 1/8" (708)	22 1/4" (565)	7.62 (0.71)	4.33 (0.40)	32 1/2" (825)	11.61 (1.08)	
TW2646	4.79	(0.44)	27 1/8" (708)	24 3/4" (628)	8.31 (0.77)	4.73 (0.44)	28 1/2" (711)	12.49 (1.16)	
TW26410	5.08	(0.47)	27 1/8" (708)	26 1/4" (666)	9.01 (0.84)	5.10 (0.47)	24 1/2" (622)	13.36 (1.24)	
TW2652	5.47	(0.51)	27 1/8" (708)	28 1/4" (717)	9.70 (0.90)	5.49 (0.51)	20 1/2" (520)	14.24 (1.32)	
TW2656 ◊	5.85	(0.54)	27 1/8" (708)	30 1/4" (768)	10.39 (0.96)	5.88 (0.55)	16 1/2" (418)	15.12 (1.41)	
TW26510 ◊	6.24	(0.58)	27 1/8" (708)	32 1/4" (819)	11.09 (1.03)	6.26 (0.58)	12 1/2" (317)	16.00 (1.49)	
TW2662 ◊	6.43	(0.60)	27 1/8" (708)	33 1/4" (843)	11.78 (1.09)	6.61 (0.61)	8 1/2" (203)	16.88 (1.57)	
TW2672 ◊	7.79	(0.72)	27 1/8" (708)	40 1/4" (1022)	13.86 (1.29)	7.82 (0.73)	10 1/4" * (260) *	19.52 (1.81)	
TW2676 ◊	8.18	(0.76)	27 1/8" (708)	42 1/4" (1073)	14.56 (1.35)	8.21 (0.76)	6 1/4" * (159) *	20.40 (1.89)	
TW28210	2.95	(0.27)	29 1/8" (759)	14 1/4" (362)	5.23 (0.49)	2.98 (0.28)	48 1/2" (1231)	8.61 (0.80)	
TW2832	3.37	(0.31)	29 1/8" (759)	16 1/4" (412)	5.98 (0.56)	3.39 (0.32)	44 1/2" (1130)	9.54 (0.89)	
TW2836	3.78	(0.35)	29 1/8" (759)	18 1/4" (463)	6.73 (0.63)	3.81 (0.35)	40 1/2" (1028)	10.47 (0.97)	
TW28310	4.20	(0.39)	29 1/8" (759)	20 1/4" (514)	7.48 (0.70)	4.22 (0.39)	36 1/2" (926)	11.41 (1.06)	
TW2842	4.61	(0.43)	29 1/8" (759)	22 1/4" (565)	8.23 (0.77)	4.64 (0.43)	32 1/2" (825)	12.34 (1.15)	
TW2846	5.13	(0.48)	29 1/8" (759)	24 3/4" (628)	8.98 (0.83)	5.07 (0.47)	28 1/2" (711)	13.28 (1.23)	
TW28410	5.44	(0.51)	29 1/8" (759)	26 1/4" (666)	9.73 (0.90)	5.47 (0.51)	24 1/2" (622)	14.21 (1.32)	
TW2852 ◊	5.86	(0.54)	29 1/8" (759)	28 1/4" (717)	10.48 (0.97)	5.88 (0.55)	20 1/2" (520)	15.14 (1.41)	

* Top of Subfloor to Top of Inside Sill Stop is calculated based upon a structural header height of 6'-10 1/2" (2096) except for 7'-5" and 7'-9" heights which are calculated using a header height of 8' (2438).
 ◊ Dimensions in parentheses are in millimeters or square meters.
 ◊ Meets or exceeds clear opening area of 5.7 sq. ft. or 0.53 m², clear opening width of 20" (508) and clear opening height of 24" (610).
 * Calculated based upon a structural header height of 8' (2438).

continued on next page

Tilt-Wash Double-Hung Windows

400 SERIES WINDOWS WITH TRIPLE-PANE GLASS



Area & Opening Specifications for Tilt-Wash Double-Hung Windows With Triple-Pane Glass *(continued)*

Window Number	Clear Opening Area Sq. Ft./ (m ²)	Clear Opening in Full Open Position		Glass Area Sq. Ft./ (m ²)	Vent Area Sq. Ft./ (m ²)	Top of Subfloor to Top of Inside Sill Stop Inches/(mm)	Overall Window Area Sq. Ft./ (m ²)
		Width Inches/(mm)	Height Inches/(mm)				
TW2856 ◊	6.27 (0.58)	29 1/8" (759)	30 1/4" (768)	11.22 (1.04)	6.30 (0.59)	16 1/2" (418)	16.08 (1.49)
TW28510 ◊	6.69 (0.62)	29 1/8" (759)	32 1/4" (819)	11.97 (1.11)	6.71 (0.62)	12 1/2" (317)	17.01 (1.58)
TW2862 ◊	6.89 (0.64)	29 1/8" (759)	33 1/4" (843)	12.72 (1.18)	7.08 (0.66)	8 1/2" (203)	17.95 (1.67)
TW2872 ◊	8.35 (0.78)	29 1/8" (759)	40 1/4" (1022)	14.98 (1.39)	8.38 (0.78)	10 1/4" (260)*	20.75 (1.93)
TW2876 ◊	8.77 (0.81)	29 1/8" (759)	42 1/4" (1073)	15.72 (1.46)	8.80 (0.82)	6 1/4" (159)*	21.69 (2.01)
TW210210	3.15 (0.29)	31 7/8" (809)	14 1/4" (362)	5.62 (0.52)	3.18 (0.30)	48 1/2" (1231)	9.12 (0.85)
TW21032	3.59 (0.33)	31 7/8" (809)	16 1/4" (412)	6.42 (0.60)	3.62 (0.34)	44 1/2" (1130)	10.11 (0.94)
TW21036	4.04 (0.38)	31 7/8" (809)	18 1/4" (463)	7.23 (0.67)	4.06 (0.38)	40 1/2" (1028)	11.10 (1.03)
TW210310	4.48 (0.42)	31 7/8" (809)	20 1/4" (514)	8.03 (0.75)	4.51 (0.42)	36 1/2" (926)	12.09 (1.12)
TW21042	4.92 (0.46)	31 7/8" (809)	22 1/4" (565)	8.84 (0.82)	4.95 (0.46)	32 1/2" (825)	13.08 (1.22)
TW21046	5.48 (0.51)	31 7/8" (809)	24 3/4" (628)	9.64 (0.90)	5.41 (0.50)	28 1/2" (711)	14.07 (1.31)
TW210410 ◊	5.81 (0.54)	31 7/8" (809)	26 1/4" (666)	10.45 (0.97)	5.83 (0.54)	24 1/2" (622)	15.05 (1.40)
TW21052 ◊	6.25 (0.58)	31 7/8" (809)	28 1/4" (717)	11.25 (1.05)	6.28 (0.58)	20 1/2" (520)	16.04 (1.49)
TW21056 ◊	6.69 (0.62)	31 7/8" (809)	30 1/4" (768)	12.06 (1.12)	6.72 (0.62)	16 1/2" (418)	17.03 (1.59)
TW210510 ◊	7.14 (0.66)	31 7/8" (809)	32 1/4" (819)	12.86 (1.20)	7.16 (0.67)	12 1/2" (317)	18.02 (1.67)
TW21062 ◊	7.35 (0.68)	31 7/8" (809)	33 1/4" (843)	13.67 (1.27)	7.55 (0.70)	8 1/2" (203)	19.01 (1.77)
TW21072 ◊	8.91 (0.83)	31 7/8" (810)	40 1/4" (1022)	16.08 (1.49)	8.94 (0.83)	10 1/4" (260)*	21.99 (2.04)
TW21076 ◊	9.35 (0.87)	31 7/8" (810)	42 1/4" (1073)	16.90 (1.57)	9.38 (0.87)	6 1/4" (159)*	22.98 (2.13)
TW30210	3.35 (0.31)	33 1/8" (860)	14 1/4" (362)	6.01 (0.56)	3.38 (0.31)	48 1/2" (1231)	9.63 (0.90)
TW3032	3.82 (0.36)	33 1/8" (860)	16 1/4" (412)	6.87 (0.64)	3.85 (0.36)	44 1/2" (1130)	10.67 (0.99)
TW3036	4.29 (0.40)	33 1/8" (860)	18 1/4" (463)	7.73 (0.72)	4.32 (0.40)	40 1/2" (1028)	11.72 (1.09)
TW30310	4.76 (0.44)	33 1/8" (860)	20 1/4" (514)	8.59 (0.80)	4.79 (0.45)	36 1/2" (926)	12.76 (1.19)
TW3042	5.23 (0.49)	33 1/8" (860)	22 1/4" (565)	9.45 (0.88)	5.26 (0.49)	32 1/2" (825)	13.81 (1.28)
TW3046 ◊	5.82 (0.54)	33 1/8" (860)	24 3/4" (628)	10.31 (0.96)	5.75 (0.53)	28 1/2" (711)	14.85 (1.38)
TW30410 ◊	6.17 (0.57)	33 1/8" (860)	26 1/4" (666)	11.17 (1.04)	6.20 (0.58)	24 1/2" (622)	15.90 (1.48)
TW3052 ◊	6.64 (0.62)	33 1/8" (860)	28 1/4" (717)	12.03 (1.12)	6.67 (0.62)	20 1/2" (520)	16.95 (1.58)
TW3056 ◊	7.11 (0.66)	33 1/8" (860)	30 1/4" (768)	12.89 (1.20)	7.14 (0.66)	16 1/2" (418)	17.99 (1.67)
TW30510 ◊	7.58 (0.70)	33 1/8" (860)	32 1/4" (819)	13.75 (1.28)	7.61 (0.71)	12 1/2" (317)	19.04 (1.77)
TW3062 ◊	7.81 (0.73)	33 1/8" (860)	33 1/4" (843)	14.61 (1.36)	8.03 (0.75)	8 1/2" (203)	20.08 (1.87)
TW3072 ◊	9.47 (0.88)	33 1/8" (860)	40 1/4" (1022)	17.20 (1.60)	9.50 (0.88)	10 1/4" (260)*	23.22 (2.16)
TW3076 ◊	9.94 (0.92)	33 1/8" (860)	42 1/4" (1073)	18.06 (1.68)	9.97 (0.93)	6 1/4" (159)*	24.27 (2.25)
TW34210	3.74 (0.35)	37 1/8" (962)	14 1/4" (362)	6.79 (0.63)	3.78 (0.35)	48 1/2" (1231)	10.65 (0.99)
TW3432	4.27 (0.40)	37 1/8" (962)	16 1/4" (412)	7.76 (0.72)	4.30 (0.40)	44 1/2" (1130)	11.81 (1.10)
TW3436	4.80 (0.45)	37 1/8" (962)	18 1/4" (463)	8.73 (0.81)	4.83 (0.45)	40 1/2" (1028)	12.97 (1.21)
TW34310	5.32 (0.49)	37 1/8" (962)	20 1/4" (514)	9.70 (0.90)	5.35 (0.50)	36 1/2" (926)	14.12 (1.31)
TW3442	5.85 (0.54)	37 1/8" (962)	22 1/4" (565)	10.67 (0.99)	5.88 (0.55)	32 1/2" (825)	15.28 (1.42)
TW3446 ◊	6.51 (0.60)	37 1/8" (962)	24 3/4" (628)	11.64 (1.08)	6.42 (0.60)	28 1/2" (711)	16.43 (1.53)
TW34410 ◊	6.90 (0.64)	37 1/8" (962)	26 1/4" (666)	12.61 (1.17)	6.93 (0.64)	24 1/2" (622)	17.59 (1.63)
TW3452 ◊	7.43 (0.69)	37 1/8" (962)	28 1/4" (717)	13.58 (1.26)	7.46 (0.69)	20 1/2" (520)	18.75 (1.74)
TW3456 ◊	7.95 (0.74)	37 1/8" (962)	30 1/4" (768)	14.55 (1.35)	7.98 (0.74)	16 1/2" (418)	19.90 (1.85)
TW34510 ◊	8.48 (0.79)	37 1/8" (962)	32 1/4" (819)	15.53 (1.44)	8.51 (0.79)	12 1/2" (317)	21.06 (1.96)
TW3462 ◊	8.73 (0.81)	37 1/8" (962)	33 1/4" (843)	16.50 (1.53)	8.98 (0.83)	8 1/2" (203)	22.22 (2.06)
TW3472 ◊	10.59 (0.98)	37 1/8" (962)	40 1/4" (1022)	19.42 (1.80)	10.62 (0.99)	10 1/4" (260)*	25.69 (2.39)
TW3476 ◊	11.11 (1.03)	37 1/8" (962)	42 1/4" (1073)	20.38 (1.89)	11.14 (1.04)	6 1/4" (159)*	26.85 (2.49)
TW38210	4.14 (0.39)	41 7/8" (1064)	14 1/4" (362)	7.56 (0.70)	4.17 (0.39)	48 1/2" (1231)	11.68 (1.09)
TW3832	4.72 (0.44)	41 7/8" (1064)	16 1/4" (412)	8.64 (0.80)	4.76 (0.44)	44 1/2" (1130)	12.94 (1.20)
TW3836	5.30 (0.49)	41 7/8" (1064)	18 1/4" (463)	9.72 (0.90)	5.34 (0.50)	40 1/2" (1028)	14.21 (1.32)
TW38310	5.88 (0.55)	41 7/8" (1064)	20 1/4" (514)	10.81 (1.00)	5.92 (0.55)	36 1/2" (926)	15.48 (1.44)
TW3842	6.47 (0.60)	41 7/8" (1064)	22 1/4" (565)	11.89 (1.11)	6.50 (0.60)	32 1/2" (825)	16.75 (1.56)
TW3846 ◊	7.19 (0.67)	41 7/8" (1064)	24 3/4" (628)	12.97 (1.21)	7.10 (0.66)	28 1/2" (711)	18.01 (1.67)
TW38410 ◊	7.63 (0.71)	41 7/8" (1064)	26 1/4" (666)	14.05 (1.31)	7.66 (0.71)	24 1/2" (622)	19.28 (1.79)
TW3852 ◊	8.21 (0.76)	41 7/8" (1064)	28 1/4" (717)	15.14 (1.41)	8.25 (0.77)	20 1/2" (520)	20.55 (1.91)
TW3856 ◊	8.79 (0.82)	41 7/8" (1064)	30 1/4" (768)	16.22 (1.51)	8.83 (0.82)	16 1/2" (418)	21.62 (2.01)
TW38510 ◊	9.37 (0.87)	41 7/8" (1064)	32 1/4" (819)	17.30 (1.61)	9.41 (0.87)	12 1/2" (317)	23.08 (2.14)
TW3862 ◊	9.66 (0.90)	41 7/8" (1064)	33 1/4" (843)	18.38 (1.71)	9.92 (0.92)	8 1/2" (203)	24.35 (2.26)
TW3872 ◊	11.70 (1.09)	41 7/8" (1064)	40 1/4" (1022)	21.64 (2.01)	11.73 (1.09)	10 1/4" (260)*	28.16 (2.26)
TW3876 ◊	12.29 (1.14)	41 7/8" (1064)	42 1/4" (1073)	22.72 (2.11)	12.32 (1.14)	6 1/4" (159)*	29.43 (2.73)

* Top of Subfloor to Top of Inside Sill Stop is calculated based upon a structural header height of 6'-10 1/2" (2096) except for 7'-5" and 7'-9" heights which are calculated using a header height of 8' (2438).

◊ Dimensions in parentheses are in millimeters or square meters.

◊ Meets or exceeds clear opening area of 5.7 sq. ft. or 0.53 m², clear opening width of 20" (508) and clear opening height of 24" (610).

* Calculated based upon a structural header height of 8' (2438).

Tilt-Wash Double-Hung Windows

400 SERIES WINDOWS WITH TRIPLE-PANE GLASS



Area & Opening Specifications for Tilt-Wash Double-Hung Windows With Triple-Pane Glass – Cottage Sash

Window Number	Clear Opening Area Sq. Ft./ (m ²)	Clear Opening in Full Open Position		Glass Area Sq. Ft./ (m ²)	Vent Area Sq. Ft./ (m ²)	Top of Subfloor to Top of Inside Sill Stop Inches/ (mm)	Overall Window Area Sq. Ft./ (m ²)
		Width Inches/ (mm)	Height Inches/ (mm)				
TW18310C	1.97 (0.18)	17 7/8" (454)	15 3/4" (401)	4.17 (0.39)	1.95 (0.18)	37 1/8" (944)	7.34 (0.68)
TW1842C	2.21 (0.21)	17 7/8" (454)	17 3/4" (452)	4.58 (0.43)	2.20 (0.20)	33 1/8" (843)	7.94 (0.74)
TW1846C	2.46 (0.23)	17 7/8" (454)	19 3/4" (503)	5.00 (0.46)	2.45 (0.23)	29 1/8" (741)	8.54 (0.79)
TW18410C	2.46 (0.23)	17 7/8" (454)	19 3/4" (503)	5.42 (0.50)	2.45 (0.23)	25 1/8" (639)	9.14 (0.85)
TW1852C	2.71 (0.25)	17 7/8" (454)	21 3/4" (553)	5.84 (0.54)	2.70 (0.25)	21 1/8" (538)	9.74 (0.90)
TW1856C	3.02 (0.28)	17 7/8" (454)	24 1/4" (617)	6.25 (0.58)	3.01 (0.28)	17 1/8" (436)	10.34 (0.96)
TW18510C	2.96 (0.27)	17 7/8" (454)	23 1/4" (604)	6.67 (0.62)	2.95 (0.27)	26 11/16" (677)	10.94 (1.02)
TW1862C	3.21 (0.30)	17 7/8" (454)	25 1/4" (655)	7.09 (0.66)	3.20 (0.30)	22 11/16" (576)	11.54 (1.07)
TW20310C	2.40 (0.22)	21 1/8" (556)	15 3/4" (401)	5.28 (0.49)	2.39 (0.22)	37 1/8" (944)	8.69 (0.81)
TW2042C	2.71 (0.25)	21 1/8" (556)	17 3/4" (452)	5.81 (0.54)	2.69 (0.25)	33 1/8" (843)	9.41 (0.87)
TW2046C	3.01 (0.28)	21 1/8" (556)	19 3/4" (503)	6.33 (0.59)	3.00 (0.28)	29 1/8" (741)	10.12 (0.94)
TW20410C	3.01 (0.28)	21 1/8" (556)	19 3/4" (503)	6.86 (0.64)	3.00 (0.28)	25 1/8" (639)	10.83 (1.01)
TW2052C	3.32 (0.31)	21 1/8" (556)	21 3/4" (553)	7.39 (0.69)	3.30 (0.31)	21 1/8" (538)	11.54 (1.07)
TW2056C	3.70 (0.34)	21 1/8" (556)	24 1/4" (617)	7.92 (0.74)	3.68 (0.34)	17 1/8" (436)	12.25 (1.14)
TW20510C	3.62 (0.34)	21 1/8" (556)	23 3/4" (604)	8.45 (0.78)	3.60 (0.33)	26 11/16" (677)	12.96 (1.20)
TW2062C	3.93 (0.36)	21 1/8" (556)	25 3/4" (655)	8.97 (0.83)	3.91 (0.36)	22 11/16" (576)	13.68 (1.27)
TW24310C	2.84 (0.26)	25 1/8" (657)	15 3/4" (401)	6.39 (0.59)	2.82 (0.26)	37 1/8" (944)	10.05 (0.93)
TW2442C	3.20 (0.30)	25 1/8" (657)	17 3/4" (452)	7.03 (0.65)	3.18 (0.30)	33 1/8" (843)	10.87 (1.01)
TW2446C	3.56 (0.33)	25 1/8" (657)	19 3/4" (503)	7.67 (0.71)	3.54 (0.33)	29 1/8" (741)	11.70 (1.09)
TW24410C	3.56 (0.33)	25 1/8" (657)	19 3/4" (503)	8.31 (0.77)	3.54 (0.33)	25 1/8" (639)	12.52 (1.16)
TW2452C	3.92 (0.36)	25 1/8" (657)	21 3/4" (553)	8.94 (0.83)	3.90 (0.36)	21 1/8" (538)	13.34 (1.24)
TW2456C	4.37 (0.41)	25 1/8" (657)	24 1/4" (617)	9.58 (0.89)	4.35 (0.40)	17 1/8" (436)	14.17 (1.32)
TW24510C	4.28 (0.40)	25 1/8" (657)	23 3/4" (604)	10.22 (0.95)	4.26 (0.40)	26 11/16" (677)	14.99 (1.39)
TW2462C	4.64 (0.43)	25 1/8" (657)	25 3/4" (655)	10.86 (1.01)	4.62 (0.43)	22 11/16" (576)	15.81 (1.47)
TW26310C	3.06 (0.28)	27 1/8" (708)	15 3/4" (401)	6.94 (0.64)	3.04 (0.28)	37 1/8" (944)	10.73 (1.00)
TW2642C	3.45 (0.32)	27 1/8" (708)	17 3/4" (452)	7.64 (0.71)	3.43 (0.32)	33 1/8" (843)	11.61 (1.08)
TW2646C	3.84 (0.36)	27 1/8" (708)	19 3/4" (503)	8.33 (0.77)	3.82 (0.35)	29 1/8" (741)	12.49 (1.16)
TW26410C	3.84 (0.36)	27 1/8" (708)	19 3/4" (503)	9.03 (0.84)	3.82 (0.35)	25 1/8" (639)	13.36 (1.24)
TW2652C	4.22 (0.39)	27 1/8" (708)	21 3/4" (553)	9.72 (0.90)	4.20 (0.39)	21 1/8" (538)	14.24 (1.32)
TW2656C	4.71 (0.44)	27 1/8" (708)	24 1/4" (617)	10.42 (0.97)	4.69 (0.44)	17 1/8" (436)	15.12 (1.40)
TW26510C	4.61 (0.43)	27 1/8" (708)	23 3/4" (604)	11.11 (1.03)	4.59 (0.43)	26 11/16" (677)	16.00 (1.49)
TW2662C	5.00 (0.46)	27 1/8" (708)	25 3/4" (655)	11.81 (1.10)	4.98 (0.46)	22 11/16" (576)	16.88 (1.57)
TW28310C	3.28 (0.30)	29 1/8" (759)	15 3/4" (401)	7.50 (0.70)	3.26 (0.30)	37 1/8" (944)	11.41 (1.06)
TW2842C	3.70 (0.34)	29 1/8" (759)	17 3/4" (452)	8.25 (0.77)	3.67 (0.34)	33 1/8" (843)	12.34 (1.15)
TW2846C	4.11 (0.38)	29 1/8" (759)	19 3/4" (503)	9.00 (0.84)	4.09 (0.38)	29 1/8" (741)	13.28 (1.23)
TW28410C	4.11 (0.38)	29 1/8" (759)	19 3/4" (503)	9.75 (0.91)	4.09 (0.38)	25 1/8" (639)	14.21 (1.32)
TW2852C	4.53 (0.42)	29 1/8" (759)	21 3/4" (553)	10.50 (0.98)	4.50 (0.42)	21 1/8" (538)	15.14 (1.41)
TW2856C	5.05 (0.47)	29 1/8" (759)	24 1/4" (617)	11.25 (1.05)	5.02 (0.47)	17 1/8" (436)	16.08 (1.49)
TW28510C	4.94 (0.46)	29 1/8" (759)	23 3/4" (604)	12.00 (1.11)	4.92 (0.46)	26 11/16" (677)	17.01 (1.58)
TW2862C	5.36 (0.50)	29 1/8" (759)	25 3/4" (655)	12.75 (1.18)	5.34 (0.50)	22 11/16" (576)	17.95 (1.67)
TW210310C	3.50 (0.33)	31 1/8" (809)	15 3/4" (401)	8.05 (0.75)	3.48 (0.32)	37 1/8" (944)	12.09 (1.12)
TW21042C	3.94 (0.37)	31 1/8" (809)	17 3/4" (452)	8.86 (0.82)	3.92 (0.36)	33 1/8" (843)	13.08 (1.21)
TW21046C	4.39 (0.41)	31 1/8" (809)	19 3/4" (503)	9.66 (0.90)	4.36 (0.41)	29 1/8" (741)	14.07 (1.31)
TW210410C	4.39 (0.41)	31 1/8" (809)	19 3/4" (503)	10.47 (0.97)	4.36 (0.41)	25 1/8" (639)	15.05 (1.40)
TW21052C	4.83 (0.45)	31 1/8" (809)	21 3/4" (553)	11.28 (1.05)	4.81 (0.45)	21 1/8" (538)	16.04 (1.49)
TW21056C	5.38 (0.50)	31 1/8" (809)	24 1/4" (617)	12.08 (1.12)	5.36 (0.50)	17 1/8" (436)	17.03 (1.58)
TW210510C	5.27 (0.49)	31 1/8" (809)	23 3/4" (604)	12.89 (1.20)	5.25 (0.49)	26 11/16" (677)	18.02 (1.67)
TW21062C ◊	5.72 (0.53)	31 1/8" (809)	25 3/4" (655)	13.69 (1.27)	5.69 (0.53)	22 11/16" (576)	19.01 (1.77)
TW30310C	3.72 (0.35)	33 1/8" (860)	15 3/4" (401)	8.61 (0.80)	3.69 (0.34)	37 1/8" (944)	12.76 (1.19)
TW3042C	4.19 (0.39)	33 1/8" (860)	17 3/4" (452)	9.47 (0.88)	4.16 (0.39)	33 1/8" (843)	13.81 (1.28)
TW3046C	4.66 (0.43)	33 1/8" (860)	19 3/4" (503)	10.33 (0.96)	4.64 (0.43)	29 1/8" (741)	14.85 (1.38)
TW30410C	4.66 (0.43)	33 1/8" (860)	19 3/4" (503)	11.19 (1.04)	4.64 (0.43)	25 1/8" (639)	15.90 (1.48)
TW3052C	5.13 (0.48)	33 1/8" (860)	21 3/4" (553)	12.05 (1.12)	5.11 (0.47)	21 1/8" (538)	16.95 (1.57)
TW3056C ◊	5.72 (0.53)	33 1/8" (860)	24 1/4" (617)	12.92 (1.20)	5.70 (0.53)	17 1/8" (436)	17.99 (1.67)
TW30510C	5.60 (0.52)	33 1/8" (860)	23 3/4" (604)	13.78 (1.28)	5.58 (0.52)	26 11/16" (677)	19.04 (1.77)
TW3062C ◊	6.07 (0.56)	33 1/8" (860)	25 3/4" (655)	14.64 (1.36)	6.05 (0.56)	22 11/16" (576)	20.08 (1.87)
TW34310C	4.16 (0.39)	37 1/8" (962)	15 3/4" (401)	9.72 (0.90)	4.13 (0.38)	37 1/8" (944)	14.12 (1.31)

• Top of Subfloor to Top of Inside Sill Stop is calculated based upon a structural header height of 6'-10 1/2" (2096). continued on next page
 • Dimensions in parentheses are in millimeters or square meters.
 ◊ Meets or exceeds clear opening area of 5.7 sq. ft. or 0.53 m², clear opening width of 20" (508) and clear opening height of 24" (610).

Tilt-Wash Double-Hung Windows

400 SERIES WINDOWS WITH TRIPLE-PANE GLASS



Area & Opening Specifications for Tilt-Wash Double-Hung Windows With Triple-Pane Glass – Cottage Sash *(continued)*

Window Number	Clear Opening Area		Clear Opening in Full Open Position		Glass Area	Vent Area	Top of Subfloor to Top of Inside Sill Stop	Overall Window Area
	Sq. Ft./	(m ²)	Width Inches/(mm)	Height Inches/(mm)				
TW3442C	4.68	(0.44)	37 7/8" (962)	17 3/4" (452)	10.69 (0.99)	4.66 (0.43)	33 1/8" (843)	15.28 (1.42)
TW3446C	5.21	(0.48)	37 7/8" (962)	19 3/4" (503)	11.66 (1.08)	5.18 (0.48)	29 1/8" (741)	16.43 (1.53)
TW34410C	5.21	(0.48)	37 7/8" (962)	19 3/4" (503)	12.64 (1.17)	5.18 (0.48)	25 1/8" (639)	17.59 (1.63)
TW3452C	5.74	(0.53)	37 7/8" (962)	21 3/4" (553)	13.61 (1.26)	5.71 (0.53)	21 1/8" (538)	18.75 (1.74)
TW3456C ◊	6.40	(0.59)	37 7/8" (962)	24 1/4" (617)	14.58 (1.35)	6.37 (0.59)	17 1/8" (436)	19.90 (1.85)
TW34510C	6.26	(0.58)	37 7/8" (962)	23 3/4" (604)	15.55 (1.44)	6.24 (0.58)	26 11/16" (677)	21.06 (1.96)
TW3462C ◊	6.79	(0.63)	37 7/8" (962)	25 3/4" (655)	16.53 (1.54)	6.76 (0.63)	22 11/16" (576)	22.22 (2.06)
TW38310C	4.60	(0.43)	41 7/8" (1064)	15 3/4" (401)	10.83 (1.01)	4.56 (0.42)	37 1/8" (944)	15.48 (1.44)
TW3842C	5.18	(0.48)	41 7/8" (1064)	17 3/4" (452)	11.91 (1.11)	5.15 (0.48)	33 1/8" (843)	16.75 (1.56)
TW3846C	5.76	(0.54)	41 7/8" (1064)	19 3/4" (503)	12.99 (1.21)	5.73 (0.53)	29 1/8" (741)	18.01 (1.67)
TW38410C	5.76	(0.54)	41 7/8" (1064)	19 3/4" (503)	14.08 (1.31)	5.73 (0.53)	25 1/8" (639)	19.28 (1.79)
TW3852C	6.34	(0.59)	41 7/8" (1064)	21 3/4" (553)	15.16 (1.41)	6.31 (0.59)	21 1/8" (538)	20.55 (1.91)
TW3856C ◊	7.07	(0.66)	41 7/8" (1064)	24 1/4" (617)	16.25 (1.51)	7.04 (0.65)	17 1/8" (436)	21.82 (2.03)
TW38510C	6.93	(0.64)	41 7/8" (1064)	23 3/4" (604)	17.33 (1.61)	6.89 (0.64)	26 11/16" (677)	23.08 (2.14)
TW3862C ◊	7.51	(0.70)	41 7/8" (1064)	25 3/4" (655)	18.41 (1.71)	7.47 (0.69)	22 11/16" (576)	24.35 (2.26)

• Top of Subfloor to Top of Inside Sill Stop is calculated based upon a structural header height of 6'-10 1/2" (2096).
 • Dimensions in parentheses are in millimeters or square meters.
 ◊ Meets or exceeds clear opening area of 5.7 sq. ft. or 0.53 m², clear opening width of 20" (508) and clear opening height of 24" (610).

Tilt-Wash Double-Hung Windows

400 SERIES WINDOWS WITH TRIPLE-PANE GLASS



Area & Opening Specifications for Tilt-Wash Double-Hung Windows With Triple-Pane Glass – Reverse Cottage Sash

Window Number	Clear Opening Area Sq. Ft./ (m ²)		Clear Opening in Full Open Position		Glass Area Sq. Ft./ (m ²)	Vent Area Sq. Ft./ (m ²)	Top of Subfloor to Top of Inside Sill Stop Inches/(mm)		Overall Window Area Sq. Ft./ (m ²)
			Width Inches/(mm)	Height Inches/(mm)					
TW18310RC	2.08	(0.19)	17 7/8" (454)	16 3/4" (425)	4.17 (0.39)	2.05 (0.19)	37 11/16" (944)	7.37 (0.68)	
TW1842RC	2.33	(0.22)	17 7/8" (454)	18 3/4" (476)	4.58 (0.43)	2.30 (0.21)	33 11/16" (843)	7.94 (0.74)	
TW1846RC	2.58	(0.24)	17 7/8" (454)	20 3/4" (527)	5.00 (0.46)	2.55 (0.24)	29 11/16" (741)	8.54 (0.79)	
TW18410RC	2.58	(0.24)	17 7/8" (454)	20 3/4" (527)	5.42 (0.50)	2.55 (0.24)	25 11/16" (639)	9.14 (0.85)	
TW1852RC	2.83	(0.26)	17 7/8" (454)	22 3/4" (578)	5.84 (0.54)	2.80 (0.26)	21 11/16" (538)	9.74 (0.90)	
TW1856RC	3.04	(0.28)	17 7/8" (454)	24 3/8" (620)	6.25 (0.58)	2.98 (0.28)	17 11/16" (436)	10.34 (0.96)	
TW18510RC	3.08	(0.29)	17 7/8" (454)	24 3/4" (629)	6.67 (0.62)	3.05 (0.28)	26 11/16" (677)	10.94 (1.02)	
TW1862RC	3.33	(0.31)	17 7/8" (454)	26 3/4" (679)	7.09 (0.66)	3.29 (0.31)	22 11/16" (576)	11.54 (1.07)	
TW20310RC	2.55	(0.24)	21 1/8" (556)	16 3/4" (425)	5.28 (0.49)	2.51 (0.23)	37 11/16" (944)	8.69 (0.81)	
TW2042RC	2.85	(0.27)	21 1/8" (556)	18 3/4" (476)	5.81 (0.54)	2.81 (0.26)	33 11/16" (843)	9.41 (0.87)	
TW2046RC	3.16	(0.29)	21 1/8" (556)	20 3/4" (527)	6.33 (0.59)	3.12 (0.29)	29 11/16" (741)	10.12 (0.94)	
TW20410RC	3.16	(0.29)	21 1/8" (556)	20 3/4" (527)	6.86 (0.64)	3.12 (0.29)	25 11/16" (639)	10.83 (1.01)	
TW2052RC	3.46	(0.32)	21 1/8" (556)	22 3/4" (578)	7.39 (0.69)	3.42 (0.32)	21 11/16" (538)	11.54 (1.07)	
TW2056RC	3.71	(0.35)	21 1/8" (556)	24 3/8" (620)	7.92 (0.74)	3.65 (0.34)	17 11/16" (436)	12.25 (1.14)	
TW20510RC	3.77	(0.35)	21 1/8" (556)	24 3/4" (629)	8.45 (0.78)	3.73 (0.35)	26 11/16" (677)	12.96 (1.20)	
TW2062RC	4.07	(0.38)	21 1/8" (556)	26 3/4" (679)	8.97 (0.83)	4.03 (0.37)	22 11/16" (576)	13.68 (1.27)	
TW24310RC	3.02	(0.28)	25 1/8" (657)	16 3/4" (425)	6.39 (0.59)	2.97 (0.28)	37 11/16" (944)	10.05 (0.93)	
TW2442RC	3.38	(0.31)	25 1/8" (657)	18 3/4" (476)	7.03 (0.65)	3.33 (0.31)	33 11/16" (843)	10.87 (1.01)	
TW2446RC	3.74	(0.35)	25 1/8" (657)	20 3/4" (527)	7.67 (0.71)	3.69 (0.34)	29 11/16" (741)	11.70 (1.09)	
TW24410RC	3.74	(0.35)	25 1/8" (657)	20 3/4" (527)	8.31 (0.77)	3.69 (0.34)	25 11/16" (639)	12.52 (1.16)	
TW2452RC	4.10	(0.38)	25 1/8" (657)	22 3/4" (578)	8.94 (0.83)	4.05 (0.38)	21 11/16" (538)	13.34 (1.24)	
TW2456RC	4.39	(0.41)	25 1/8" (657)	24 3/8" (620)	9.58 (0.89)	4.32 (0.40)	17 11/16" (436)	14.17 (1.32)	
TW24510RC	4.46	(0.41)	25 1/8" (657)	24 3/4" (629)	10.22 (0.95)	4.41 (0.41)	26 11/16" (677)	14.99 (1.39)	
TW2462RC	4.82	(0.45)	25 1/8" (657)	26 3/4" (679)	10.86 (1.01)	4.77 (0.44)	22 11/16" (576)	15.81 (1.47)	
TW26310RC	3.25	(0.30)	27 1/8" (708)	16 3/4" (425)	6.94 (0.64)	3.19 (0.30)	37 11/16" (944)	10.73 (1.00)	
TW2642RC	3.64	(0.34)	27 1/8" (708)	18 3/4" (476)	7.64 (0.71)	3.58 (0.33)	33 11/16" (843)	11.61 (1.08)	
TW2646RC	4.02	(0.37)	27 1/8" (708)	20 3/4" (527)	8.33 (0.77)	3.97 (0.37)	29 11/16" (741)	12.49 (1.16)	
TW26410RC	4.02	(0.37)	27 1/8" (708)	20 3/4" (527)	9.03 (0.84)	3.97 (0.37)	25 11/16" (639)	13.36 (1.24)	
TW2652RC	4.41	(0.41)	27 1/8" (708)	22 3/4" (578)	9.72 (0.90)	4.36 (0.40)	21 11/16" (538)	14.24 (1.32)	
TW2656RC	4.73	(0.44)	27 1/8" (708)	24 3/8" (620)	10.42 (0.97)	4.65 (0.43)	17 11/16" (436)	15.12 (1.40)	
TW26510RC	4.80	(0.45)	27 1/8" (708)	24 3/4" (629)	11.11 (1.03)	4.75 (0.44)	26 11/16" (677)	16.00 (1.49)	
TW2662RC	5.19	(0.48)	27 1/8" (708)	26 3/4" (679)	11.81 (1.10)	5.13 (0.48)	22 11/16" (576)	16.88 (1.57)	
TW28310RC	3.48	(0.32)	29 1/8" (759)	16 3/4" (425)	7.50 (0.70)	3.42 (0.32)	37 11/16" (944)	11.41 (1.06)	
TW2842RC	3.90	(0.36)	29 1/8" (759)	18 3/4" (476)	8.25 (0.77)	3.84 (0.36)	33 11/16" (843)	12.34 (1.15)	
TW2846RC	4.31	(0.40)	29 1/8" (759)	20 3/4" (527)	9.00 (0.84)	4.25 (0.40)	29 11/16" (741)	13.28 (1.23)	
TW28410RC	4.31	(0.40)	29 1/8" (759)	20 3/4" (527)	9.75 (0.91)	4.25 (0.40)	25 11/16" (639)	14.21 (1.32)	
TW2852RC	4.73	(0.44)	29 1/8" (759)	22 3/4" (578)	10.50 (0.98)	4.67 (0.43)	21 11/16" (538)	15.14 (1.41)	
TW2856RC	5.07	(0.47)	29 1/8" (759)	24 3/8" (620)	11.25 (1.05)	4.98 (0.46)	17 11/16" (436)	16.08 (1.49)	
TW28510RC	5.14	(0.48)	29 1/8" (759)	24 3/4" (629)	12.00 (1.11)	5.09 (0.47)	26 11/16" (677)	17.01 (1.58)	
TW2862RC	5.56	(0.52)	29 1/8" (759)	26 3/4" (679)	12.75 (1.18)	5.50 (0.51)	22 11/16" (576)	17.95 (1.67)	
TW210310RC	3.71	(0.34)	31 1/8" (809)	16 3/4" (425)	8.05 (0.75)	3.65 (0.34)	37 11/16" (944)	12.09 (1.12)	
TW21042RC	4.16	(0.39)	31 1/8" (809)	18 3/4" (476)	8.86 (0.82)	4.10 (0.38)	33 11/16" (843)	13.08 (1.22)	
TW21046RC	4.60	(0.43)	31 1/8" (809)	20 3/4" (527)	9.66 (0.90)	4.54 (0.42)	29 11/16" (741)	14.07 (1.31)	
TW210410RC	4.60	(0.43)	31 1/8" (809)	20 3/4" (527)	10.47 (0.97)	4.54 (0.42)	25 11/16" (639)	15.05 (1.40)	
TW21052RC	5.04	(0.47)	31 1/8" (809)	22 3/4" (578)	11.28 (1.05)	4.98 (0.46)	21 11/16" (538)	16.04 (1.49)	
TW21056RC	5.41	(0.50)	31 1/8" (809)	24 3/8" (620)	12.08 (1.12)	5.31 (0.49)	17 11/16" (436)	17.03 (1.58)	
TW210510RC	5.49	(0.51)	31 1/8" (809)	24 3/4" (629)	12.89 (1.20)	5.43 (0.50)	26 11/16" (677)	18.02 (1.67)	
TW21062RC ◊	5.93	(0.55)	31 1/8" (809)	26 3/4" (679)	13.69 (1.27)	5.87 (0.55)	22 11/16" (576)	19.01 (1.77)	
TW30310RC	3.95	(0.37)	33 1/8" (860)	16 3/4" (425)	8.61 (0.80)	3.88 (0.36)	37 11/16" (944)	12.76 (1.19)	
TW3042RC	4.42	(0.41)	33 1/8" (860)	18 3/4" (476)	9.47 (0.88)	4.35 (0.40)	33 11/16" (843)	13.81 (1.28)	
TW3046RC	4.89	(0.45)	33 1/8" (860)	20 3/4" (527)	10.33 (0.96)	4.82 (0.45)	29 11/16" (741)	14.85 (1.38)	
TW30410RC	4.89	(0.45)	33 1/8" (860)	20 3/4" (527)	11.19 (1.04)	4.82 (0.45)	25 11/16" (639)	15.90 (1.48)	
TW3052RC	5.36	(0.50)	33 1/8" (860)	22 3/4" (578)	12.05 (1.12)	5.29 (0.49)	21 11/16" (538)	16.95 (1.57)	
TW3056RC ◊	5.75	(0.53)	33 1/8" (860)	24 3/8" (620)	12.92 (1.20)	5.65 (0.52)	17 11/16" (436)	17.99 (1.67)	
TW30510RC ◊	5.83	(0.54)	33 1/8" (860)	24 3/4" (629)	13.78 (1.28)	5.76 (0.54)	26 11/16" (677)	19.04 (1.77)	
TW3062RC ◊	6.30	(0.59)	33 1/8" (860)	26 3/4" (679)	14.64 (1.36)	6.24 (0.58)	22 11/16" (576)	20.08 (1.87)	
TW34310RC	4.41	(0.41)	37 1/8" (962)	16 3/4" (425)	9.72 (0.90)	4.34 (0.40)	37 11/16" (944)	14.12 (1.31)	

• Top of Subfloor to Top of Inside Sill Stop is calculated based upon a structural header height of 6'-10 1/2" (2096). continued on next page
 • Dimensions in parentheses are in millimeters or square meters.
 ◊ Meets or exceeds clear opening area of 5.7 sq. ft. or 0.53 m², clear opening width of 20" (508) and clear opening height of 24" (610).

Tilt-Wash Double-Hung Windows

400 SERIES WINDOWS WITH TRIPLE-PANE GLASS



Area & Opening Specifications for Tilt-Wash Double-Hung Windows With Triple-Pane Glass – Reverse Cottage Sash *(continued)*

Window Number	Clear Opening Area Sq. Ft./ (m ²)		Clear Opening in Full Open Position		Glass Area Sq. Ft./ (m ²)	Vent Area Sq. Ft./ (m ²)		Top of Subfloor to Top of Inside Sill Stop Inches/(mm)		Overall Window Area Sq. Ft./ (m ²)	
			Width Inches/(mm)	Height Inches/(mm)							
TW3442RC	4.94	(0.46)	37 7/8" (962)	18 3/4" (476)	10.69	(0.99)	4.86	(0.45)	33 11/16" (843)	15.28	(1.42)
TW3446RC	5.46	(0.51)	37 7/8" (962)	20 3/4" (527)	11.66	(1.08)	5.39	(0.50)	29 11/16" (741)	16.43	(1.53)
TW34410RC	5.46	(0.51)	37 7/8" (962)	20 3/4" (527)	12.64	(1.17)	5.39	(0.50)	25 11/16" (639)	17.59	(1.63)
TW3452RC	5.99	(0.56)	37 7/8" (962)	22 3/4" (578)	13.61	(1.26)	5.92	(0.55)	21 11/16" (538)	18.75	(1.74)
TW3456RC ◊	6.43	(0.60)	37 7/8" (962)	24 3/8" (620)	14.58	(1.35)	6.31	(0.59)	17 11/16" (436)	19.90	(1.85)
TW34510RC ◊	6.52	(0.61)	37 7/8" (962)	24 3/4" (629)	15.55	(1.44)	6.44	(0.60)	26 11/16" (677)	21.06	(1.96)
TW3462RC ◊	7.04	(0.65)	37 7/8" (962)	26 3/8" (679)	16.53	(1.54)	6.97	(0.65)	22 11/16" (576)	22.22	(2.06)
TW38310RC	4.88	(0.45)	41 7/8" (1064)	16 3/4" (425)	10.83	(1.01)	4.80	(0.45)	17 11/16" (944)	15.48	(1.44)
TW3842RC	5.46	(0.51)	41 7/8" (1064)	18 3/4" (476)	11.91	(1.11)	5.38	(0.50)	26 11/16" (843)	16.75	(1.56)
TW3846RC	6.04	(0.56)	41 7/8" (1064)	20 3/4" (527)	12.99	(1.21)	5.96	(0.55)	22 11/16" (741)	18.01	(1.67)
TW38410RC	6.04	(0.56)	41 7/8" (1064)	20 3/4" (527)	14.08	(1.31)	5.96	(0.55)	37 11/16" (639)	19.28	(1.79)
TW3852RC	6.62	(0.62)	41 7/8" (1064)	22 3/4" (578)	15.16	(1.41)	6.54	(0.61)	33 11/16" (538)	20.55	(1.91)
TW3856RC ◊	7.10	(0.66)	41 7/8" (1064)	24 3/8" (620)	16.25	(1.51)	6.98	(0.65)	29 11/16" (436)	21.62	(2.01)
TW38510RC ◊	7.20	(0.67)	41 7/8" (1064)	24 3/4" (629)	17.33	(1.61)	7.12	(0.66)	25 11/16" (677)	23.08	(2.14)
TW3862RC ◊	7.79	(0.72)	41 7/8" (1064)	26 3/4" (679)	18.41	(1.71)	7.71	(0.72)	21 11/16" (576)	24.35	(2.26)

• Top of Subfloor to Top of Inside Sill Stop is calculated based upon a structural header height of 6'-10 1/2" (2096).
 • Dimensions in parentheses are in millimeters or square meters.
 ◊ Meets or exceeds clear opening area of 5.7 sq. ft. or 0.53 m², clear opening width of 20" (508) and clear opening height of 24" (610).

Tilt-Wash Double-Hung Windows

400 SERIES WINDOWS WITH TRIPLE-PANE GLASS



Area Specifications for Tilt-Wash Transom Windows With Triple-Pane Glass

Window Number	Glass Area Sq. Ft./ (m ²)	Overall Window Area Sq. Ft./ (m ²)
TWT1810	0.56 (0.05)	1.80 (0.17)
TWT1815	1.32 (0.12)	2.90 (0.27)
TWT1817	1.52 (0.14)	3.20 (0.30)
TWT18111	1.94 (0.18)	3.80 (0.35)
TWT1821	2.15 (0.20)	4.10 (0.38)
TWT1823	2.35 (0.22)	4.40 (0.41)
TWT1827	2.77 (0.26)	5.00 (0.47)
TWT1831	3.39 (0.32)	5.90 (0.55)
TWT2010	0.70 (0.07)	2.14 (0.20)
TWT2015	1.67 (0.16)	3.44 (0.32)
TWT2017	1.93 (0.18)	3.79 (0.35)
TWT20111	2.46 (0.23)	4.50 (0.42)
TWT2021	2.72 (0.25)	4.86 (0.45)
TWT2023	2.98 (0.28)	5.22 (0.49)
TWT2027	3.51 (0.33)	5.93 (0.55)
TWT2031	4.30 (0.40)	7.00 (0.65)
TWT2410	0.85 (0.08)	2.47 (0.23)
TWT2415	2.02 (0.19)	3.97 (0.37)
TWT2417	2.34 (0.22)	4.38 (0.41)
TWT24111	2.98 (0.28)	5.21 (0.48)
TWT2421	3.29 (0.31)	5.62 (0.52)
TWT2423	3.61 (0.34)	6.03 (0.56)
TWT2427	4.25 (0.40)	6.85 (0.64)
TWT2431	5.21 (0.48)	8.09 (0.75)
TWT2610	0.93 (0.09)	2.64 (0.25)
TWT2615	2.19 (0.20)	4.24 (0.39)
TWT2617	2.54 (0.24)	4.68 (0.44)
TWT26111	3.23 (0.30)	5.56 (0.52)
TWT2621	3.58 (0.33)	6.00 (0.56)
TWT2623	3.93 (0.37)	6.44 (0.60)
TWT2627	4.62 (0.43)	7.32 (0.68)
TWT2631	5.66 (0.53)	8.63 (0.80)
TWT2810	1.00 (0.09)	2.80 (0.26)
TWT2815	2.37 (0.22)	4.51 (0.42)
TWT2817	2.74 (0.26)	4.98 (0.46)
TWT28111	3.49 (0.32)	5.91 (0.55)
TWT2821	3.87 (0.36)	6.38 (0.59)
TWT2823	4.24 (0.39)	6.84 (0.64)
TWT2827	4.99 (0.46)	7.78 (0.72)
TWT2831	6.12 (0.57)	9.18 (0.85)
TWT21010	1.07 (0.10)	2.97 (0.28)
TWT21015	2.55 (0.24)	4.78 (0.44)
TWT21017	2.95 (0.27)	5.27 (0.49)
TWT210111	3.75 (0.35)	6.26 (0.58)
TWT21021	4.15 (0.39)	6.76 (0.63)
TWT21023	4.56 (0.42)	7.25 (0.67)
TWT21027	5.36 (0.50)	8.24 (0.77)
TWT21031	6.57 (0.61)	9.73 (0.90)
TWT3010	1.15 (0.11)	3.14 (0.29)
TWT3015	2.72 (0.25)	5.05 (0.47)
TWT3017	3.15 (0.29)	5.57 (0.52)
TWT30111	4.01 (0.37)	6.61 (0.61)
TWT3021	4.44 (0.41)	7.14 (0.66)
TWT3023	4.87 (0.45)	7.66 (0.71)
TWT3027	5.73 (0.53)	8.70 (0.81)
TWT3031	7.02 (0.65)	10.27 (0.95)
TWT3410	1.30 (0.12)	3.47 (0.32)
TWT3415	3.07 (0.29)	5.58 (0.52)
TWT3417	3.56 (0.33)	6.16 (0.57)
TWT34111	4.53 (0.42)	7.32 (0.68)

Window Number	Glass Area Sq. Ft./ (m ²)	Overall Window Area Sq. Ft./ (m ²)
TWT3421	5.02 (0.47)	7.89 (0.73)
TWT3423	5.50 (0.51)	8.47 (0.79)
TWT3427	6.47 (0.60)	9.63 (0.90)
TWT3431	7.93 (0.74)	11.36 (1.06)
TWT3810	1.45 (0.14)	3.80 (0.35)
TWT3815	3.42 (0.32)	6.12 (0.57)
TWT3817	3.97 (0.37)	6.75 (0.63)
TWT38111	5.05 (0.47)	8.02 (0.75)
TWT3821	5.59 (0.52)	8.65 (0.80)
TWT3823	6.13 (0.57)	9.29 (0.86)
TWT3827	7.21 (0.67)	10.55 (0.98)
TWT3831	8.84 (0.82)	12.46 (1.16)
TWT31010	1.51 (0.14)	3.94 (0.37)
TWT4210	1.66 (0.15)	4.28 (0.40)
TWT41010	1.95 (0.18)	4.94 (0.46)
TWT5610	2.25 (0.21)	5.61 (0.52)
TWT6210	2.55 (0.24)	6.28 (0.58)

* Dimensions in parentheses are in square meters.

Custom Sizes and Specification Formulas



Available in 1/8" (3) increments between minimum and maximum widths and heights. Windows can also be custom sized to match standard sizes ending in a 1/16" (1.5) of an inch. Some restrictions apply; contact your Andersen supplier. For minimum rough opening dimensions for joined windows, see specific joining instruction guides. Measurement guide for custom-size windows can be found at andersenwindows.com/measure.

Tilt-Wash Double-Hung Windows With Triple-Pane Glass

Equal Sash

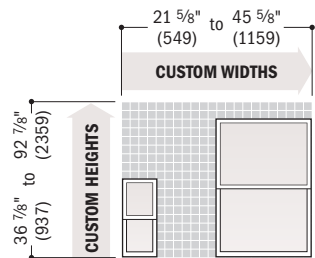

Cottage Sash

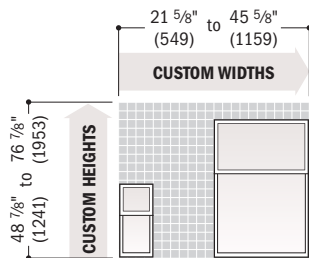

Reverse Cottage Sash

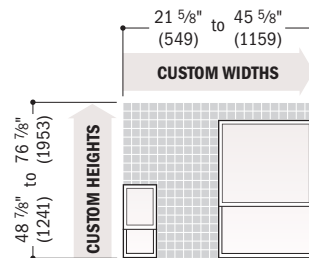

Equal sash windows greater than 6'-4 7/8" (1953) in height and cottage and reverse cottage sash windows greater than 5'-8 7/8" (1749) in height have interior and exterior brackets. Interior brackets, located on both sides of the meeting rail, must be flipped up for proper product performance.

	Clear Opening Width = window width - 1.852" (47) x 2 Contact your Andersen supplier for clear opening height.		Minimum R.O. Width = window width + 1/2" (51) Height = window height + 0"
	Vent Opening Vent opening formulas are dependent on window size; contact your Andersen supplier.		Unobst. Glass Width = window width - 3.376" (86) Height: Upper Sash = upper sash height - 3.035" (77) Lower Sash = lower sash height - 3.831" (97)

Tilt-Wash Transom Windows With Triple-Pane Glass

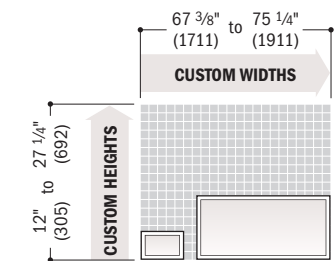
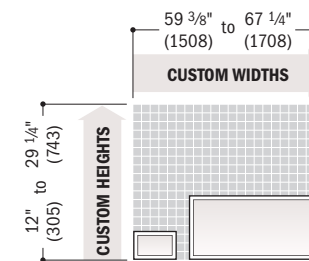
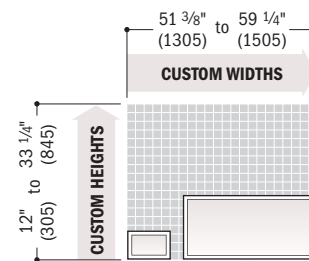
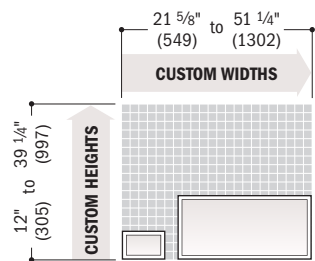

	Minimum R.O. Width = window width + 1/2" (51) Height = window height + 0		Unobst. Glass Picture Window Width = window width - 4.924" (125) Height = window height - 7.531" (191)	Transom Window Width = window width - 6.625" (168) Height = window height - 6.625" (168)
--	---	--	---	---

• **Clear Opening** formulas provide dimensions for determining area available for egress. **Vent Opening** formulas provide dimensions for determining area available for passage of air. **Minimum R.O.** (minimum rough opening) formulas provide minimum rough opening width and height dimensions. **Unobst. Glass** (unobstructed glass) formulas provide dimensions for determining area available for passage of light.
 • Refer to andersenwindows.com/measure for detailed instructions on how to properly measure for custom-size windows.
 • Dimensions in parentheses are in millimeters.

Tilt-Wash Double-Hung Windows

Grille Options for Tilt-Wash Windows With Triple-Pane Glass

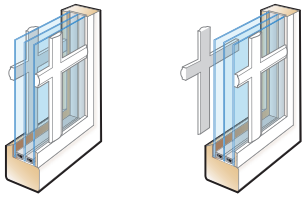

Simulated Divided Light

Simulated divided light (SDL) grilles are permanently applied to the exterior and interior of the window, without a spacer between the glass and are available in $\frac{3}{4}$ " (19) or $\frac{7}{8}$ " (22) widths. Interior grilles are available in natural wood or prefinished white and can be ordered permanently applied or removable for easier cleaning.

Tilt-Wash Double-Hung Window Grille Profiles

Exterior grilles on double-hung windows with triple-pane glass have a lower chamfer.

Interior

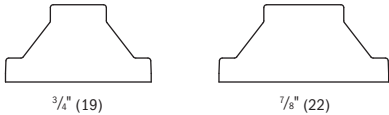

Exterior



Tilt-Wash Transom Window Grille Profiles

Interior & Exterior

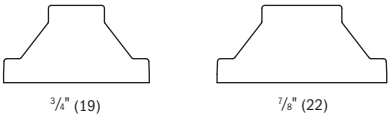

Finelight™ Grille-Between-the-Glass

Andersen® Finelight grilles-between-the-glass are installed between the glass panes and feature a contoured $\frac{3}{4}$ " (19) profile.

Tilt-Wash Double-Hung Windows

Grille Patterns

	Prairie A	Colonial	Short Fractional		Prairie A	Colonial	
Tilt-Wash Double-Hung Windows With Triple-Pane Glass	 Equal	 Cottage	 Equal	 Cottage	Tilt-Wash Transom Windows With Triple-Pane Glass	 Prairie A	 Colonial

Patterns for double-hung windows are also available in Upper Sash Only (USO) configurations.

Number of lights and overall pattern varies with window size. Patterns may not be available in all configurations or sizes. Specified equal light are also available.

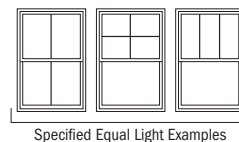

400 SERIES WINDOWS WITH TRIPLE-PANE GLASS



Details for Tilt-Wash Double-Hung Windows With Triple-Pane Glass

Scale 1 1/2" (38) = 1'-0" (305) – 1:8

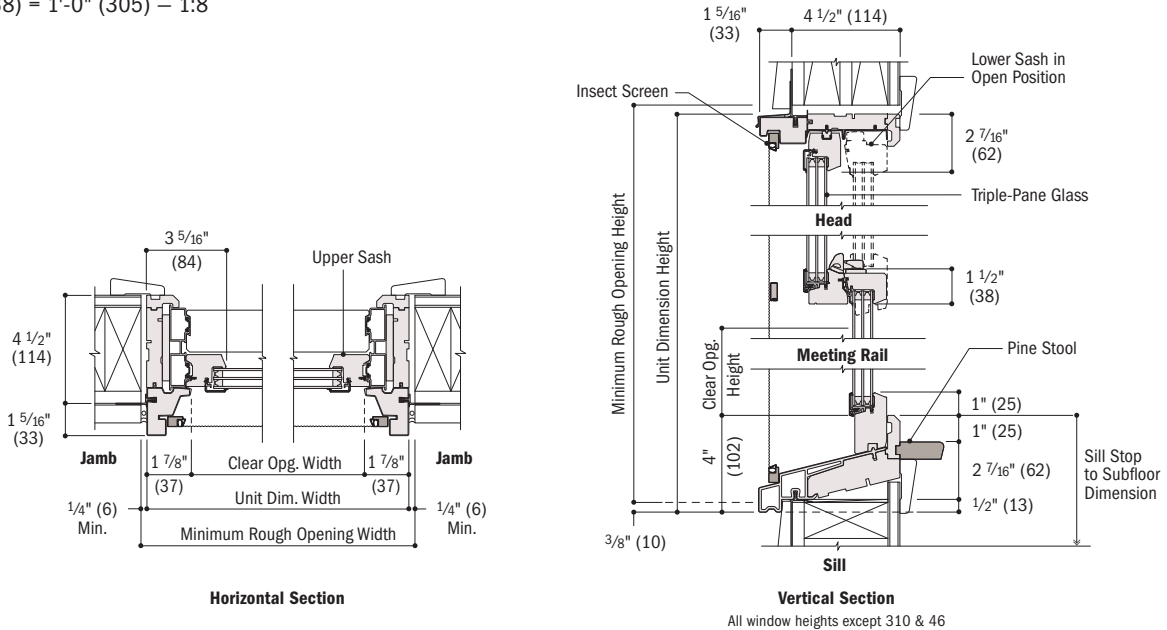

310 and 46 Height Windows Only:

Upper Sash Meeting Rail
(higher location on
310 and 46 heights)

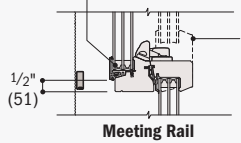

Note: Location of support bar on optional insect screen aligns with meeting rail location on 310 and 46 window heights.

Details for Tilt-Wash Transom Windows With Triple-Pane Glass

Scale 1 1/2" (38) = 1'-0" (305) – 1:8

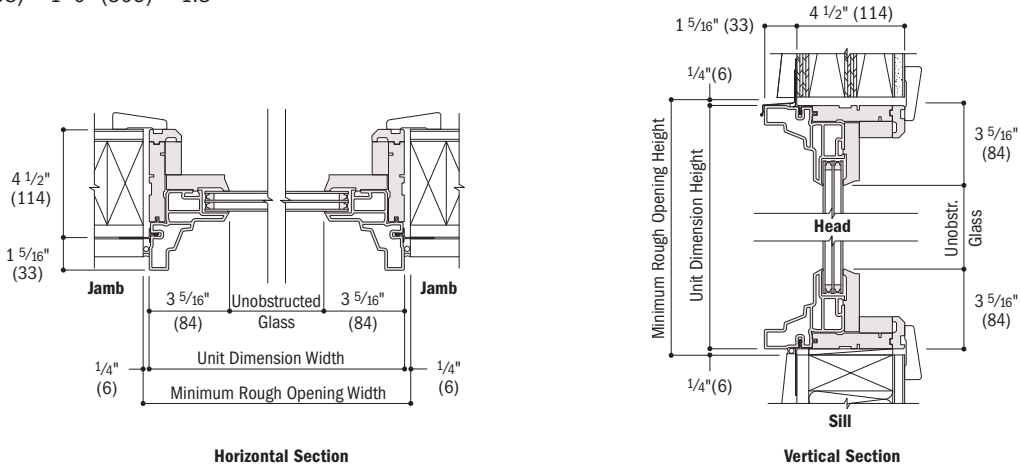

- Light-colored areas are parts included with window. Dark-colored areas are additional Andersen® parts required to complete window assembly as shown.
- **Minimum rough openings may need to be increased to allow for use of building wraps, flashing, sill panning, brackets, fasteners or other items.**
- Details are for illustration only and are not intended to represent product installation methods or materials. Refer to product installation guides at andersenwindows.com.
- Dimensions in parentheses are in millimeters.

Tilt-Wash Double-Hung Windows

Horizontal (stack) Joining Detail

Scale 1 1/2" (38) = 1'-0" (305) – 1:8

Overall Window Dimension Height

Sum of individual window heights plus 1/16" (1.5) per join.

Overall Rough Opening Height

Overall window dimension height.*

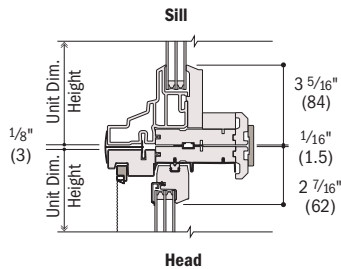

Vertical Section
Transom (TWT) over Tilt-Wash Double-Hung

Vertical (ribbon) Joining Detail

Scale 1 1/2" (38) = 1'-0" (305) – 1:8

Overall Window Dimension Width

Sum of individual window widths plus 1/16" (1.5) per join.

Overall Rough Opening Width

Overall window dimension width plus 1/2" (13).

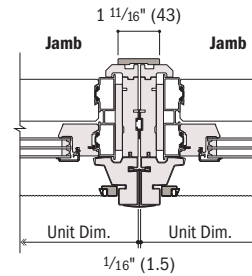

Horizontal Section
Tilt-Wash Double-Hung to Tilt-Wash Double-Hung

Joined combinations are limited by weight restrictions, contact your Andersen supplier for more information.

For more information on joining, refer to pages 42-49.

Separate Rough Openings Detail

Scale 1 1/2" (38) = 1'-0" (305) – 1:8

To meet structural requirements or to achieve a wider joined appearance, windows may be installed into separate rough openings having vertical support by others in combination with Andersen® exterior filler and exterior vinyl trim.

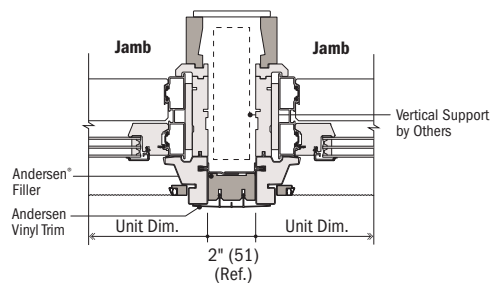

Horizontal Section
Tilt-Wash Double-Hung and Tilt-Wash Double-Hung

- *Light-colored areas are parts included with window. Dark-colored areas are additional Andersen® parts required to complete window assembly as shown.
- **Minimum rough openings may need to be increased to allow for use of building wraps, flashing, sill panning, brackets, fasteners or other items.**
- Details are for illustration only and are not intended to represent product installation methods or materials. Refer to product installation guides at andersenwindows.com.
- Consult with an architect or structural engineer regarding minimum requirements for structural support members between adjacent rough openings.
- Dimensions in parentheses are in millimeters.
- For stacks where bottom unit in combination is a double-hung or picture window with a sloped sill. If bottom window has a flat sill add 1/2" (13) to the overall window dimension height.

400 SERIES WINDOWS WITH TRIPLE-PANE GLASS



Table of Sizes for Casement/Awning Half Circle and Quarter Circle Windows With Triple-Pane Glass

Scale 1/8" (3) = 1'-0" (305) – 1:96

Window Dimension	2'-0 1/8" (613)	2'-4 3/8" (721)	2'-7 1/2" (800)	2'-11 15/16" (913)	4'-0" (1219)
Minimum Rough Opening	2'-0 5/8" (625)	2'-4 7/8" (733)	2'-8" (813)	3'-0 1/2" (927)	4'-0 1/2" (1232)
Unobstructed Glass (Half & Quarter Circle)	19 1/2" (495)	23 3/4" (603)	26 7/8" (683)	31 5/16" (795)	43 3/8" (1102)
Radius	12 1/16" (306)	14 3/16" (360)	15 3/4" (400)	18** (457)	24" (610)
	1'-2 3/8" (365) 1'-2 7/8" (378) 9 3/4" (248)	1'-4 1/2" (419) 1'-5" (432) 11 7/8" (302)	1'-6" (458) 1'-6 1/2" (470) 13 7/16" (341)	1'-8 1/4" (514) 1'-8 3/4" (527) 15 5/8" (397)	2'-2 5/16" (668) 2'-2 7/8" (683) 21 1/16" (551)
Radius	24" (610)	28 1/4" (718)	31 3/8" (797)	35 13/16" (910)	
	2'-0 1/8" (613) 2'-0 5/8" (625) 19 1/2" (495)	2'-4 3/8" (721) 2'-4 7/8" (733) 23 3/4" (603)	2'-7 1/2" (800) 2'-8" (813) 26 7/8" (683)	2'-11 15/16" (913) 3'-0 1/2" (927) 31 5/16" (795)	
	CTC1	CTCW1	CTCX1	CTCXW1	CTC2
	C12, C125, C13, C135, C14, C145, C15, C155, C16, CTR2010, AR21, AN21, A21, AW21, A212, A213	CW12, CW125, CW13, CW135, CW14, CW145, CW15, CW155, CW16, CTR2410, AR251, AN251, A251, AW251, AX251	CX125, CX13, CX135, CX14, CX145, CX15, CX155, CTR2810, AR281, AN281, A281, AW281, AX281, AXW281	CXW13, CXW135, CXW14, CXW145, CTR3010, PTR3010, P3030, P3035, P3040, P3045, P3050, P3055, P3060, AR31, AN31, A31, AW31, AX31, AXW31, A335, A312, AXW312, A313, AP32V, PA3050, PA3060	
	4'-8 1/2" (1435) 4'-9" (1448) 51 7/8" (1318) 28 1/4" (718)	5'-2 3/4" (1594) 5'-3 1/4" (1607) 58 1/8" (1476) 31 3/8" (797)	5'-11 7/8" (1826) 6'-0 3/8" (1838) 67 1/4" (1708) 35 15/16" (913)		
	2'-6 9/16" (776) 2'-7 1/8" (791) 25 15/16" (659)	2'-9 5/8" (854) 2'-10 1/8" (967) 29" (737)	3'-2 1/4" (972) 3'-2 3/4" (984) 33 5/8" (854)		
	CTCW2	CTCX2	CTC3		
	CX23, CX235, CX24, CX245, CX25, CTR5210, CTR22810, AR2281, AN2281, A2281, AW2281, AX2281, AXW2281		C32, C325, C33, C335, C34, C345, C35, CTR6010, CTR32010, PTR6010, AR61, AN61, A61, AW61, AR321, AN321, A321, AW321, P6030, P6035, P6040, P6045, P6050		

continued below

Specialty Windows

Compatible casement, awning and picture windows are shown below specialty windows.

Grille information shown on page 38. Details shown on pages 39.

• Window Dimension always refers to outside frame-to-frame dimension.
 • Minimum Rough Opening dimensions may need to be increased to allow for use of building wraps, flashing, sill panning, brackets, fasteners or other items.
 • Dimensions in parentheses are in millimeters.

400 SERIES WINDOWS WITH TRIPLE-PANE GLASS



Table of Sizes for Double-Hung Half Circle Windows With Triple-Pane Glass

Scale 1/8" (3) = 1'-0" (305) – 1:96

Window Dimension	2'-1 5/8"	2'-5 5/8"	2'-9 5/8"	3'-1 5/8"	3'-5 5/8"
	(651)	(752)	(854)	(956)	(1057)
Minimum Rough Opening	2'-2 1/8"	2'-6 1/8"	2'-10 1/8"	3'-2 1/8"	3'-6 1/8"
	(664)	(765)	(867)	(968)	(1070)
Unobstructed Glass	20 3/8"	24 3/8"	28 3/8"	32 3/8"	36 3/8"
	(518)	(619)	(721)	(822)	(924)
Radius	12 13/16" (325)	14 13/16" (376)	16 13/16" (427)	18 13/16" (478)	20 13/16" (529)
	CTN20	CTN24	CTN28	CTN30	CTN34
20210, 2032, 2036, 20310, 2042, 2046, 20410, 2052, 2056, 20510, 2062, 2072, 2076	24210, 2432, 2436, 24310, 2442, 2446, 24410, 2452, 2456, 24510, 2462, 2472, 2476	28210, 2832, 2836, 28310, 2842, 2846, 28410, 2852, 2856, 28510, 2862, 2872, 2876	30210, 3032, 3036, 30310, 3042, 3046, 30410, 3052, 3056, 30510, 3062, 3072, 3076	34210, 3432, 3436, 34310, 3442, 3446, 34410, 3452, 3456, 34510, 3462, 3472, 3476	

continued below

	5'-7 5/16"	6'-3 5/16"
	(1710)	(1913)
	5'-7 7/8"	6'-3 7/8"
	(1724)	(1927)
	62 1/16"	70 1/16"
	(1576)	(1780)
	33 11/16** (856)	37 11/16*** (957)
	CTN28-2	CTN30-2
28210-2, 2832-2, 2836-2, 28310-2, 2842-2, 2846-2, 28410-2, 2852-2, 2856-2, 28510-2, 2862-2, 2872-2, 2876-2	30210-2, 3032-2, 3036-2, 30310-2, 3042-2, 3046-2, 30410-2, 3052-2, 3056-2, 30510-2, 3062-2, 3072-2, 3076-2	

Compatible double-hung windows are shown below specialty windows.

Grille information shown on page 38.

Details shown on pages 39.

- Window Dimension always refers to outside frame-to-frame dimension.
- **Minimum Rough Opening dimensions may need to be increased to allow for use of building wraps, flashing, sill panning, brackets, fasteners or other items.**
- Dimensions in parentheses are in millimeters.
- *Actual radius of 33 21/32" (855).
- **Actual radius of 37 21/32" (956).

Specialty Windows

400 SERIES WINDOWS WITH TRIPLE-PANE GLASS



Table of Sizes for Circle Windows With Triple-Pane Glass

Scale 1/8" (3) = 1'-0" (305) – 1:96

Window Dimension	2'-0 1/8" (613)	2'-4 3/8" (721)	2'-11 15/16" (913)
Minimum Rough Opening	2'-0 5/8" (625)	2'-4 7/8" (733)	3'-0 1/2" (927)
Unobstructed Glass	19 3/4" (502)	24" (610)	31 9/16" (802)



CIR20



CIR24



CIR30

Table of Sizes for Oval Windows With Triple-Pane Glass

Scale 1/8" (3) = 1'-0" (305) – 1:96

Window Dimension	1'-7 3/4" (502)	2'-0" (610)	3'-0" (914)
Minimum Rough Opening	1'-8 1/4" (514)	2'-0 1/2" (622)	3'-0 1/2" (927)
Unobstructed Glass	15 3/8" (391)	19 3/8" (492)	31 3/8" (797)



OVL1824



OVL2030



OVL3048

Grille information shown on page 38.

Details shown on pages 39.

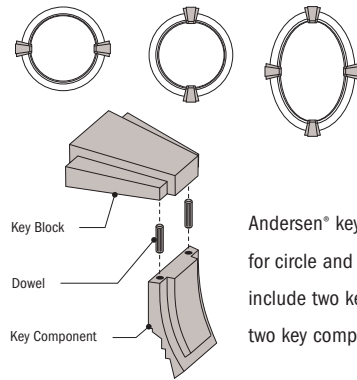

Andersen® key block kits for circle and oval windows include two key blocks and two key components.

Oval windows can be installed in a vertical or horizontal orientation.

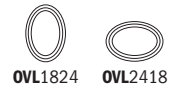



Table of Sizes for Elliptical Windows With Triple-Pane Glass

Scale 1/8" (3) = 1'-0" (305) – 1:96

Window Dimension	5'-11 1/4" (1810)	7'-11 1/4" (2419)
Minimum Rough Opening	6'-0" (1829)	8'-0" (2438)
Unobstructed Glass	66 1/4" (1683)	90 1/4" (2292)



ET6

1'-4 3/8"
(425)
1'-5 1/2"
(445)
11 7/8"
(302)

FWG6068, FWG60611, FWG6080, FWH6068, FWH60611, FWH6080, FWO6068, FWO60611, FWO6080, NLGD6068, NLGD60611, NLGD6080, ISID6068, ISID60611, ISID6076, ISID6080



ET8

1'-9"
(533)
1'-9 3/4"
(552)
16 1/8"
(410)

FWG8068, FWG80611, FWG8080, FWH8068, FWH80611, FWH8080, NLGD8068, NLGD80611, NLGD8080

Compatible 400 Series patio door sizes are shown below elliptical windows. Grille information shown on page 38. Details shown on pages 39.

• Window Dimension always refers to outside frame-to-frame dimension.
 • Minimum Rough Opening dimensions may need to be increased to allow for use of building wraps, flashing, sill panning, brackets, fasteners or other items.
 • Dimensions in parentheses are in millimeters.

Specialty Windows

Area Specifications for Casement/Awning Half Circle Windows With Triple-Pane Glass

Window Number	Glass Area Sq. Ft./ (m ²)
CTC1	1.0 (0.09)
CTCW1	1.5 (0.14)
CTCXW1	2.7 (0.25)
CTC2	5.1 (0.47)
CTCW2	7.3 (0.68)
CTC3	12.3 (1.14)
CTCX1	2.0 (0.19)
CTCX2	9.3 (0.86)

* Dimensions in parentheses are in square meters.

Area Specifications for Double-Hung Half Circle Windows With Triple-Pane Glass

Window Number	Glass Area Sq. Ft./ (m ²)
CTN20	1.1 (0.10)
CTN24	1.6 (0.15)
CTN28	2.2 (0.20)
CTN30	2.8 (0.26)
CTN34	3.6 (0.34)
CTN28-2	10.5 (0.98)
CTN30-2	13.4 (1.25)

* Dimensions in parentheses are in square meters.

Area Specifications for Quarter Circle Windows With Triple-Pane Glass

Window Number	Glass Area Sq. Ft./ (m ²)
CTQC1	1.9 (0.18)
CTQCW1	3.0 (0.28)
CTQA3	5.2 (0.48)
CTQCX1	3.8 (0.35)

* Dimensions in parentheses are in square meters.

Area Specifications for Elliptical Windows With Triple-Pane Glass

Window Number	Glass Area Sq. Ft./ (m ²)
ET6	4.3 (0.40)
ET8	8.0 (0.74)

* Dimensions in parentheses are in square meters.

Area Specifications for Circle and Oval Windows With Triple-Pane Glass

Window Number	Glass Area Sq. Ft./ (m ²)
CIR20	2.1 (0.20)
CIR24	3.0 (0.28)
CIR30	5.2 (0.48)
OVL1824	1.9 (0.18)
OVL2030	3.2 (0.30)
OVL3048	8.7 (0.81)

* Dimensions in parentheses are in square meters.

Grille Options for Specialty Windows With Triple-Pane Glass

Grilles are available for casement half circle, double-hung half circle, circle, oval and elliptical windows.

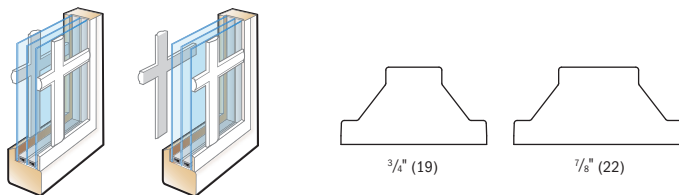

Simulated Divided Light

Simulated divided light (SDL) grilles are permanently applied to the exterior and interior of the window, without a spacer between the glass and are available in 3/4" (19) or 7/8" (22) widths. Interior grilles are available in natural wood or prefinished white and can be ordered permanently applied or removable for easier cleaning.

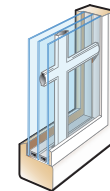

Finelight™ Grille-Between-the-Glass

Andersen® Finelight grilles-between-the-glass are installed between the glass panes and feature a contoured 3/4" (19) profile.

Grille Patterns

	Colonial	Renaissance	Sunburst
Casement/Awning Half Circle			
Double-Hung Half Circle			
Quarter Circle			
Elliptical			
Circle			
Oval			

Patterns for specialty windows may not align with patterns for picture windows when horizontally joined. **Number of lights and overall pattern varies with window size. Patterns may not be available in all configurations or sizes.**

400 SERIES WINDOWS WITH TRIPLE-PANE GLASS



Detail for Casement/Awning Half Circle Windows With Triple-Pane Glass

Scale 1 1/2" (38) = 1'-0" (305) – 1:8

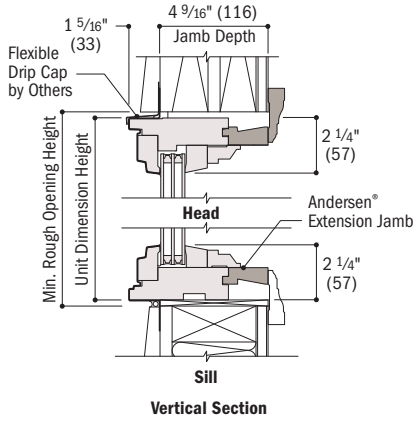

Details for Double-Hung Half Circle Windows With Triple-Pane Glass

Scale 1 1/2" (38) = 1'-0" (305) – 1:8

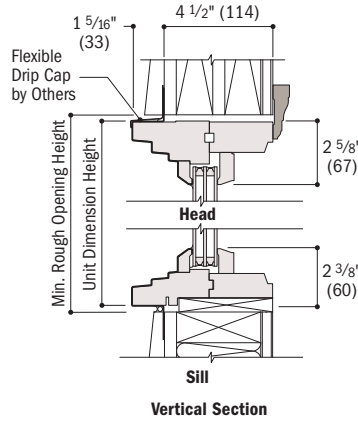

Detail for Elliptical Windows With Triple-Pane Glass

Scale 1 1/2" (38) = 1'-0" (305) – 1:8

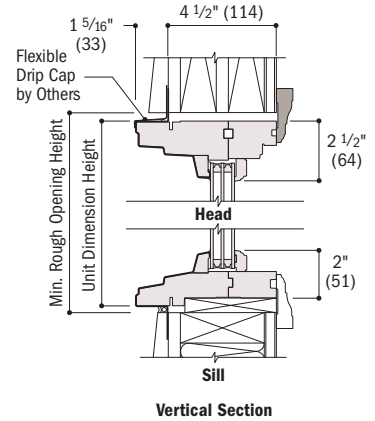

Detail for Circle Windows With Triple-Pane Glass

Scale 1 1/2" (38) = 1'-0" (305) – 1:8

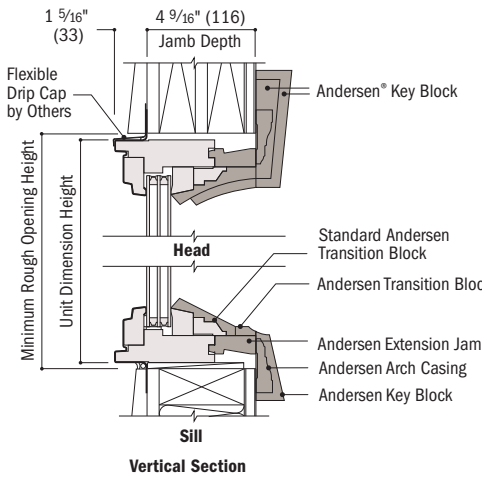

Detail for Oval Windows With Triple-Pane Glass

Scale 1 1/2" (38) = 1'-0" (305) – 1:8

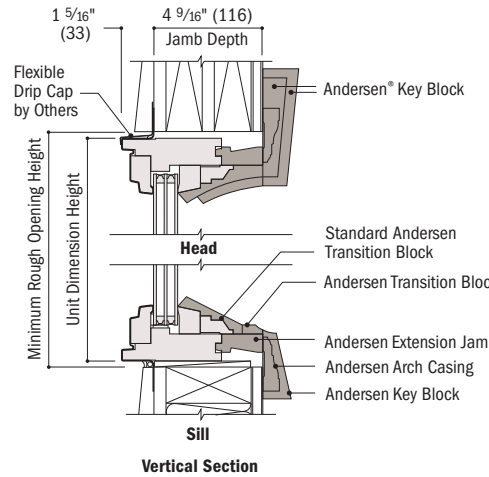

Horizontal (stack) Joining Detail

Scale 1 1/2" (38) = 1'-0" (305) – 1:8

Overall Window Dimension Height

Sum of individual window heights plus 1/8" (3) per join.

Overall Rough Opening Height

Overall window dimension height plus 5/8" (16).

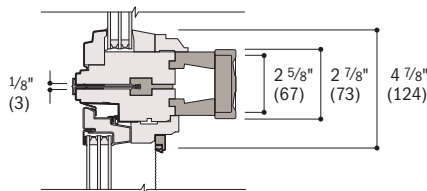

Vertical Section
Casement/Awning Half Circle Over Casement

Joined combinations are limited by weight restrictions, contact your Andersen supplier for more information.

For more information on joining, refer to pages 42-49.

- 4 9/16" (116) or 4 1/2" (114) overall jamb depth measurement is from back side of installation flange.
- Light-colored areas are parts included with window. Dark-colored areas are additional Andersen® parts required to complete window assembly as shown.
- **Minimum rough openings may need to be increased to allow for use of building wraps, flashing, sill panning, brackets, fasteners or other items.**
- Details are for illustration only and are not intended to represent product installation methods or materials. Refer to product installation guides at andersenwindows.com.
- Consult with an architect or structural engineer regarding minimum requirements for structural support members between adjacent rough openings.
- Dimensions in parentheses are in millimeters.

Specialty Windows

Complementary Specialty Windows

Andersen® complementary specialty windows are available in a variety of sizes. Fixed unit profiles may vary dependent upon shape. For specific sizes, details and joining information, contact your Andersen supplier.

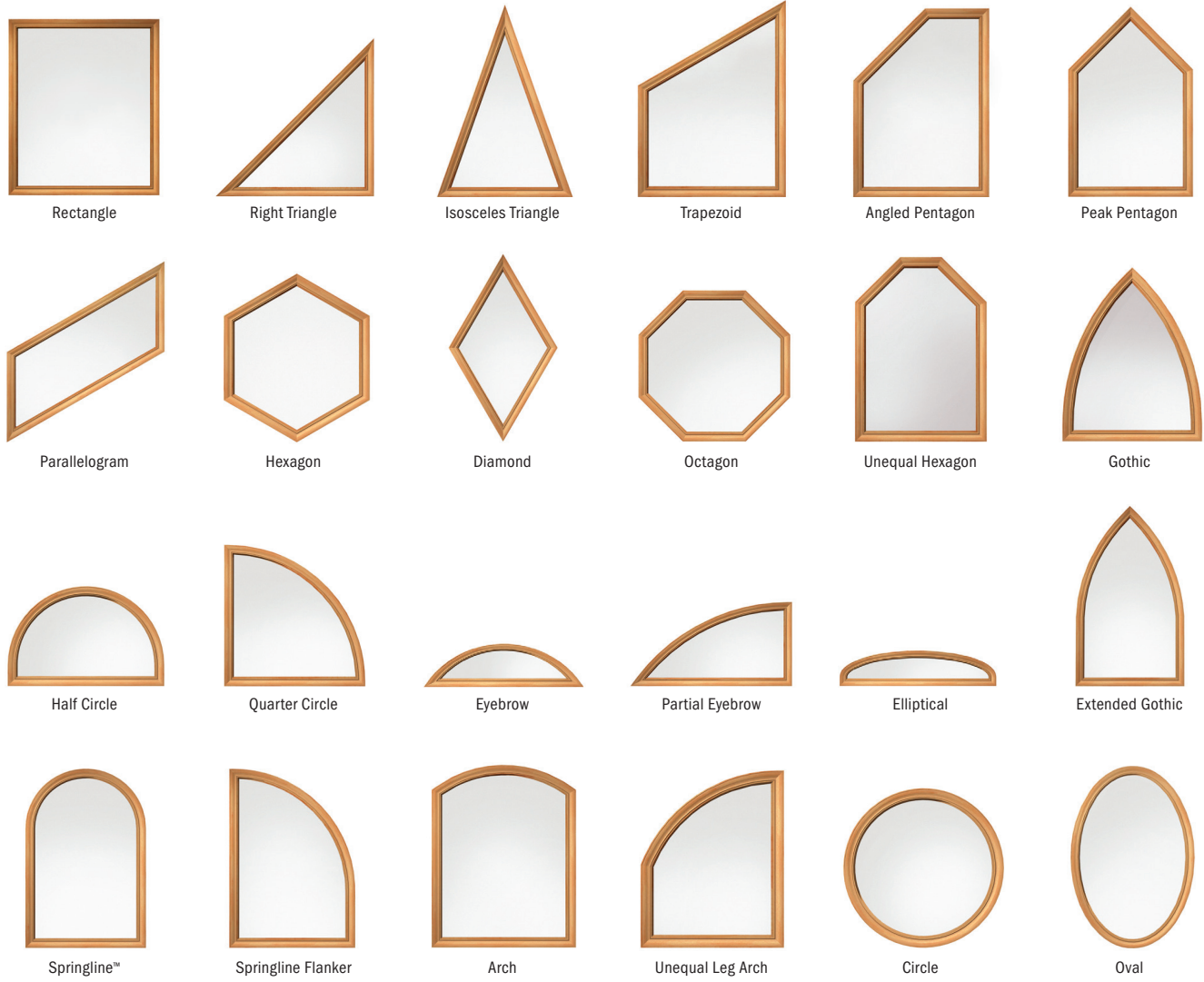

The additional specialty window shapes below are available by special order.

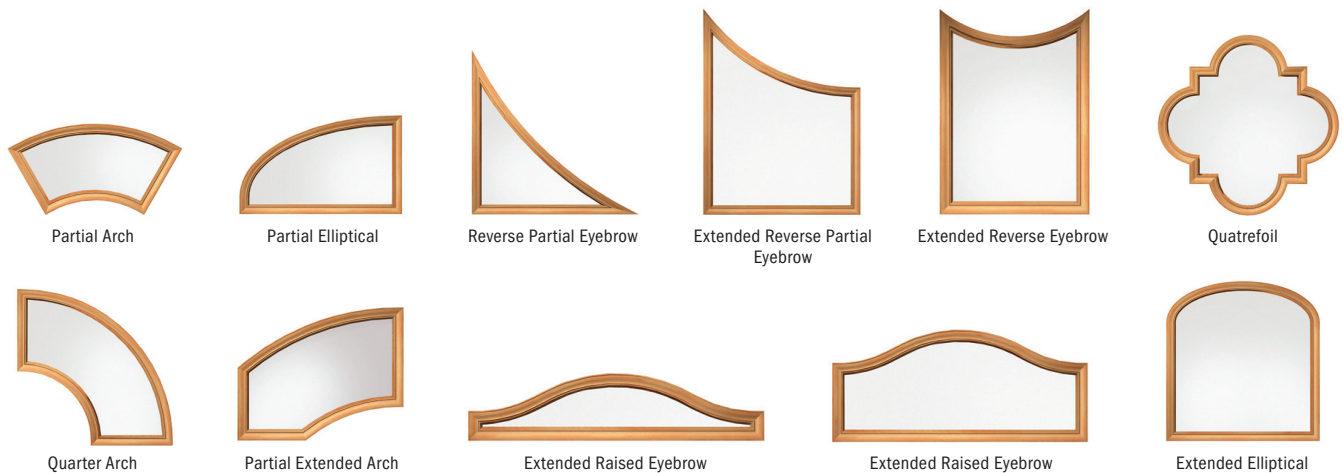

400 SERIES WINDOWS WITH TRIPLE-PANE GLASS



Details for Complementary Specialty Windows With Triple-Pane Glass

Scale 1 1/2" (38) = 1'-0" (305) – 1:8

Complements 400 Series Casement, Awning and Picture Windows

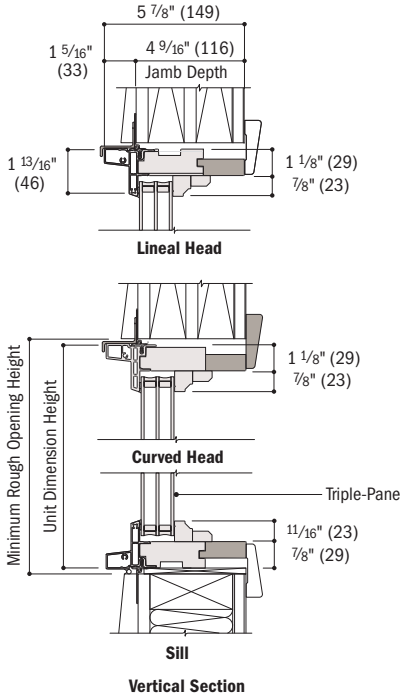

Complements 400 Series Double-Hung Windows and Patio Doors

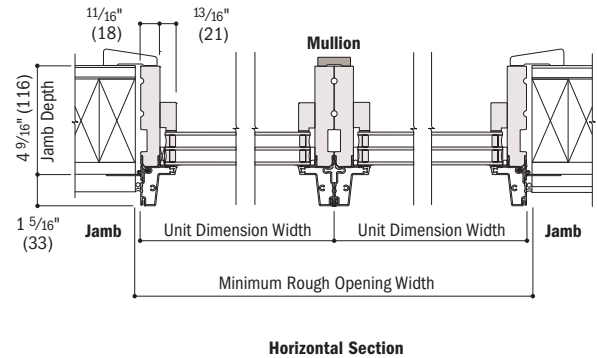
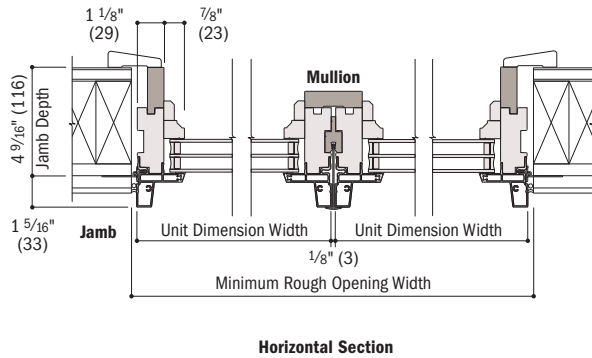
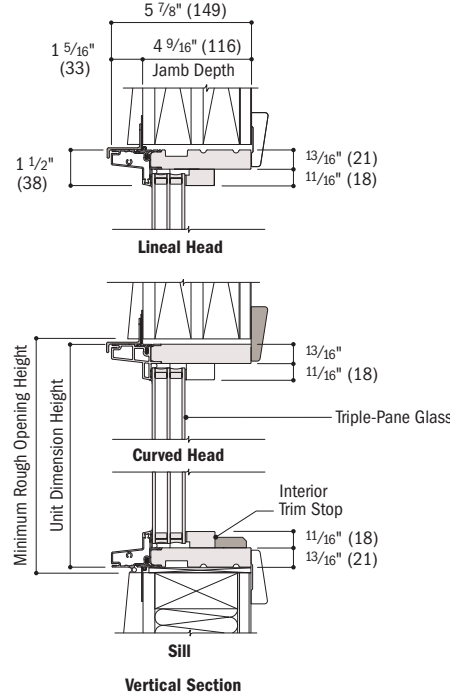

Horizontal (stack) Joining Detail

Scale 1 1/2" (38) = 1'-0" (305) – 1:8

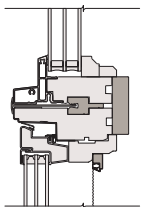

Vertical Section
 Complementary Specialty Over
 400 Series Casement Window

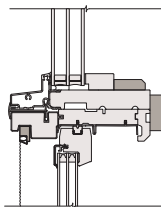

Vertical Section
 Complementary Specialty Over
 400 Series Tilt-Wash Double-Hung Window

Joined combinations are limited by weight restrictions, contact your Andersen supplier for more information.

For more information on joining, refer to pages 42-49.

- 4 9/16" (116) overall jamb depth measurement is from back side of installation flange.
- Light-colored areas are parts included with window. Dark-colored areas are additional Andersen® parts required to complete window assembly as shown.
- **Minimum rough openings may need to be increased to allow for use of building wraps, flashing, sill panning, brackets, fasteners or other items.**
- Details are for illustration only and are not intended to represent product installation methods or materials. Refer to product installation guides at andersenwindows.com.
- Dimensions in parentheses are in millimeters.

Complementary Specialty Windows

400 SERIES WINDOWS WITH TRIPLE-PANE GLASS



Andersen® Joining Materials

For a successful installation, one engineered to provide the required design pressure, it is important Andersen joining materials and installation accessories be specified by a project architect or contractor. For one- and two-way combinations, Andersen offers joining materials to meet specified performance requirements. Combinations are joined using either LVL, steel, aluminum or wood material depending on the product types. Each creates a joining system that enhances the look of Andersen products without sacrificing performance.

The addition of joining materials will affect the overall rough opening dimension. **For all joining methods, read and follow product joining installation instructions in their entirety.**

Visit andersenwindows.com for instructions.

A variety of exterior trim strips for finishing the space between joined products are available in colors to match Andersen windows and patio doors. Interior casing is available in several wood types, prefinished options sizes and style options, including laminated arch casings, decorative plinths and key blocks. Components used with each joining system will vary depending on products being joined. Contact with your Andersen supplier for more information.

Materials vary depending on type of units being joined and wind load requirements. Non-reinforced joining material is used to create alignment and positive joining between windows. Joining materials are not connected to the rough opening structure. Non-reinforced joins can also be achieved using accessory items such as V-notch gusset plates. Contact your Andersen supplier for specific performance and product recommendations.

Reinforced joining material is used to create product alignment, positive joining and load transfer between Andersen windows and patio doors and the rough opening. They provide added strength capable of withstanding a greater range of wind load pressures. The structural performance of any combination is only as high as the lowest structural performance rating of any individual unit or joining material in the combination.

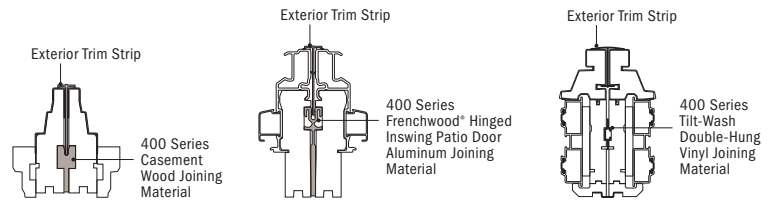

Laminated Veneer Lumber (LVL) Joining Material

LVL is available in 3/4" (19) x 4 9/16" (116) and 3/4" (19) x 6 9/16" (167) sizes and includes an aluminum exterior trim strip retainer. Available in a variety of lengths up to 10' (3048).

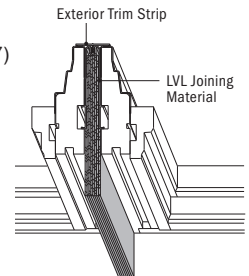

Steel Joining Material

Steel joining material is available in 8'-0 1/4" (2445), 9'-6" (2896) and 12'-6" (3810) lengths. Treated for corrosion resistance, a 4" (102) depth of material provides strength and rigidity. Adjacent windows attach to the steel joining material with screws.

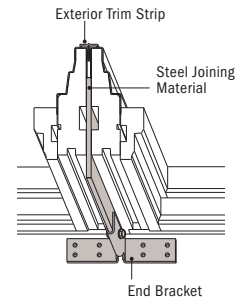

Aluminum Joining Material

Aluminum joining material is available in 6'-0 3/32" (1831) and 7'-8" (2337) lengths. High-quality aluminum provides increased stiffness and is anodized for corrosion resistance. Aluminum joining material stays within the basic jamb of the window so interior casing can be used without extension jambs. Adjacent windows attach to the aluminum joining material with screws.

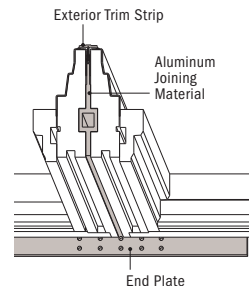

Combination Designs

*Structural performance of any combination is only as high as the lowest structural performance of any individual unit or joining material in the combination.
•Dimensions in parentheses are in millimeters.

400 SERIES WINDOWS WITH TRIPLE-PANE GLASS



1-Way Wood Joining

400 Series Casement, Awning, Picture, Transom and Complementary Specialty Windows

(A + B) + 2 = 12'-6" (3810)	70	70	58	42	32	24	20			
(A + B) + 2 = 12'-0" (3658)	70	70	58	42	32	24	20			
(A + B) + 2 = 11'-6" (3505)	70	70	58	42	32	24	20			
(A + B) + 2 = 11'-0" (3353)	70	70	58	42	32	24	20			
(A + B) + 2 = 10'-6" (3200)	70	70	58	42	32	24	20			
(A + B) + 2 = 10'-0" (3048)	70	70	58	42	32	24	20			
(A + B) + 2 = 9'-6" (2896)	70	70	58	42	32	24	20			
(A + B) + 2 = 9'-0" (2743)	70	70	58	42	32	24	20			
(A + B) + 2 = 8'-6" (2591)	70	70	58	42	32	24	20			
(A + B) + 2 = 8'-0" (2438)	70	70	58	42	32	24	20			
(A + B) + 2 = 7'-6" (2286)	70	70	58	42	32	24	20			
(A + B) + 2 = 7'-0" (2134)	70	70	58	42	32	24	20			
(A + B) + 2 = 6'-6" (1981)	70	70	58	42	32	24	20			
(A + B) + 2 = 6'-0" (1829)	70	70	58	42	32	24	20			
(A + B) + 2 = 5'-6" (1676)	70	70	58	42	32	25	20			
(A + B) + 2 = 5'-0" (1524)	70	70	58	42	32	25	21			
(A + B) + 2 = 4'-6" (1372)	70	70	58	43	33	27	22			
(A + B) + 2 = 4'-0" (1219)	70	70	59	45	35	29	24	20		
(A + B) + 2 = 3'-6" (1067)	70	70	63	48	38	31	26	22		
(A + B) + 2 = 3'-0" (914)	70	70	68	54	43	36	30	25	22	
(A + B) + 2 = 2'-6" (762)	70	70	70	62	50	42	35	30	26	22
(A + B) + 2 = 2'-0" (610)	70	70	70	70	61	51	43	37	32	27
(A + B) + 2 = 1'-6" (457)	70	70	70	70	70	67	57	49	42	35
C = (length of join)	3'-6" (1067)	4'-0" (1219)	4'-6" (1372)	5'-0" (1524)	5'-6" (1676)	6'-0" (1829)	6'-6" (1981)	7'-0" (2134)	7'-6" (2286)	8'-0" (2438)

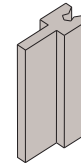
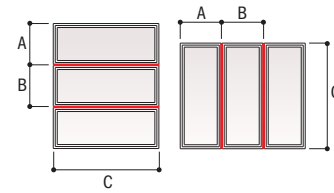

Wood Joining Material

Stacking of windows is allowed to a maximum height of 12'-6" (3810). Contact your Andersen supplier for information about taller combination heights.

Combination Designs

2-Way Wood Joining

400 Series Casement, Awning, Picture, Transom and Complementary Specialty Windows

(A + B) + 2 = 8'-6" (2591)	20									
(A + B) + 2 = 8'-0" (2438)	21									
(A + B) + 2 = 7'-6" (2286)	23									
(A + B) + 2 = 7'-0" (2134)	24									
(A + B) + 2 = 6'-6" (1981)	26	20								
(A + B) + 2 = 6'-0" (1829)	28	22								
(A + B) + 2 = 5'-6" (1676)	31	24								
(A + B) + 2 = 5'-0" (1524)	34	26	20							
(A + B) + 2 = 4'-6" (1372)	38	29	23							
(A + B) + 2 = 4'-0" (1219)	43	33	26	21						
(A + B) + 2 = 3'-6" (1067)	49	37	29	24						
(A + B) + 2 = 3'-0" (914)	57	44	34	28	23					
(A + B) + 2 = 2'-6" (762)	69	52	41	33	27	23				
(A + B) + 2 = 2'-0" (610)	70	66	52	42	34	29	23			
(A + B) + 2 = 1'-6" (457)	70	70	69	56	46	39	31	24	20	
C = (length of join)	3'-6" (1067)	4'-0" (1219)	4'-6" (1372)	5'-0" (1524)	5'-6" (1676)	6'-0" (1829)	6'-6" (1981)	7'-0" (2134)	7'-6" (2286)	

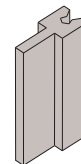
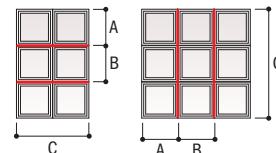

Wood Joining Material

- Numerical values in charts represent structural pressure only.
- Structural performance of any combination is only as high as the lowest structural performance of any individual unit or joining material in the combination.
- Andersen® products must be installed and anchored properly according to joining and installation guides to meet rated structural performance. Refer to product joining and installation instructions at andersenwindows.com.
- Dimensions in parentheses are in millimeters.

400 SERIES WINDOWS WITH TRIPLE-PANE GLASS



1-Way LVL Joining

400 Series Casement, Awning, Picture, Transom and Complementary Specialty Windows

4 9/16" (116) Minimum Wall Depth	Average Adjacent Window Dim.	(A + B) ÷ 2 = 6'-0" (1829)	70	70	56	45				
		(A + B) ÷ 2 = 5'-6" (1676)	70	70	61	50				
		(A + B) ÷ 2 = 5'-0" (1524)	70	70	68	55	45	36		
		(A + B) ÷ 2 = 4'-6" (1372)	70	70	70	61	51	43	37	
		(A + B) ÷ 2 = 4'-0" (1219)	70	70	70	70	58	49	42	35
		(A + B) ÷ 2 = 3'-6" (1067)	70	70	70	70	68	56	49	39
		(A + B) ÷ 2 = 3'-0" (914)	70	70	70	70	70	63	53	45
		(A + B) ÷ 2 = 2'-6" (762)	70	70	70	70	70	70	62	53
		(A + B) ÷ 2 = 2'-0" (610)	70	70	70	70	70	70	62	53
		(A + B) ÷ 2 = 1'-6" (457)	70	70	70	70	70	70	62	53
C = (length of join)	3'-6" (1067)	4'-0" (1219)	4'-6" (1372)	5'-0" (1524)	5'-6" (1676)	6'-0" (1829)	6'-6" (1981)	7'-0" (2134)		

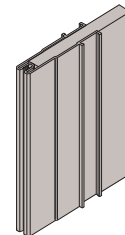
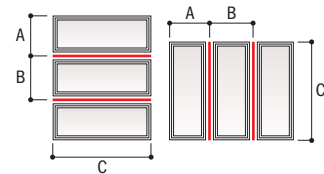

3/4" (19) x 5 3/4" (146)
LVL Joining Material
For 4 9/16" (116) jamb depths.

2-Way LVL Joining

400 Series Casement, Awning, Picture, Transom and Complementary Specialty Windows

4 9/16" (116) Minimum Wall Depth	Average Adjacent Window Dim.	(A + B) ÷ 2 = 6'-0" (1829)	65	65	51	41				
		(A + B) ÷ 2 = 5'-6" (1676)	70	70	56	45				
		(A + B) ÷ 2 = 5'-0" (1524)	70	70	62	50	41	34		
		(A + B) ÷ 2 = 4'-6" (1372)	70	70	68	55	46	38	33	
		(A + B) ÷ 2 = 4'-0" (1219)	70	70	70	62	51	43	37	32
		(A + B) ÷ 2 = 3'-6" (1067)	70	70	70	70	59	49	42	36
		(A + B) ÷ 2 = 3'-0" (914)	70	70	70	70	69	58	49	42
		(A + B) ÷ 2 = 2'-6" (762)	70	70	70	70	70	69	59	51
		(A + B) ÷ 2 = 2'-0" (610)	70	70	70	70	61	69	59	51
		(A + B) ÷ 2 = 1'-6" (457)	70	70	70	70	61	69	59	51
C = (length of join)	3'-6" (1067)	4'-0" (1219)	4'-6" (1372)	5'-0" (1524)	5'-6" (1676)	6'-0" (1829)	6'-6" (1981)	7'-0" (2134)		

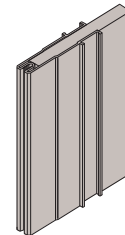
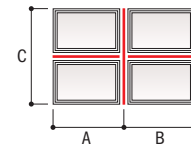

3/4" (19) x 5 3/4" (146)
LVL Joining Material
For 4 9/16" (116) jamb depths.

6 9/16" (167) Minimum Wall Depth	Average Adjacent Window Dimension	(A + B) ÷ 2 = 10'-0" (3048)	70	70	63	56	48	44	37	31	24
		(A + B) ÷ 2 = 9'-6" (2896)	70	70	63	56	48	44	37	31	24
		(A + B) ÷ 2 = 9'-0" (2743)	70	70	63	56	48	44	37	31	24
		(A + B) ÷ 2 = 8'-6" (2591)	70	70	63	56	48	44	37	31	25
		(A + B) ÷ 2 = 8'-0" (2438)	70	70	63	56	48	44	37	31	25
		(A + B) ÷ 2 = 7'-6" (2286)	70	70	63	56	48	44	38	32	26
		(A + B) ÷ 2 = 7'-0" (2134)	70	70	63	56	49	45	39	33	26
		(A + B) ÷ 2 = 6'-6" (1981)	70	70	63	57	50	46	40	34	28
		(A + B) ÷ 2 = 6'-0" (1829)	70	70	64	58	51	47	41	35	29
		(A + B) ÷ 2 = 5'-6" (1676)	70	70	66	60	54	50	44	37	30
		(A + B) ÷ 2 = 5'-0" (1524)	70	70	68	63	56	52	46	39	32
		(A + B) ÷ 2 = 4'-6" (1372)	70	70	70	67	60	56	50	43	35
		(A + B) ÷ 2 = 4'-0" (1219)	70	70	70	70	64	60	53	46	38
		(A + B) ÷ 2 = 3'-6" (1067)	70	70	70	70	70	67	60	52	42
		(A + B) ÷ 2 = 3'-0" (914)	70	70	70	70	70	70	66	57	47
		(A + B) ÷ 2 = 2'-6" (762)	70	70	70	70	70	70	70	68	56
		(A + B) ÷ 2 = 2'-0" (610)	70	70	70	70	70	70	70	70	66
		(A + B) ÷ 2 = 1'-6" (457)	70	70	70	70	70	70	70	70	70
C = (length of join)	6'-0" (1829) or less	6'-6" (1981)	7'-0" (2134)	7'-6" (2286)	8'-0" (2438)	8'-6" (2591)	9'-0" (2743)	9'-6" (2896)	10'-0" (3048)		

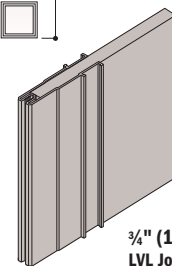
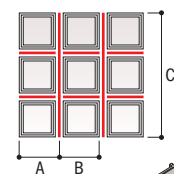

3/4" (19) x 7 3/4" (197)
LVL Joining Material
For 6 9/16" (167) jamb depths.

2-way joining must be assembled on the job site within the rough opening.

* Numerical values in charts represent structural pressure only.
 * Structural performance of any combination is only as high as the lowest structural performance of any individual unit or joining material in the combination.
 * Andersen® products must be installed and anchored properly according to joining and installation guides to meet rated structural performance. Refer to product joining and installation instructions at andersenwindows.com.
 * Dimensions in parentheses are in millimeters.

Combination Designs

400 SERIES WINDOWS WITH TRIPLE-PANE GLASS



1-Way Vinyl Joining with V-Notch Gusset Plates 400 Series Tilt-Wash Double-Hung and Transom Windows

Average Adjacent Window Dimension	(A + B) ÷ 2 = 12'-6" (3810)	50	48	41	33	29	24	22													
	(A + B) ÷ 2 = 12'-0" (3658)	50	48	41	33	29	24	22													
	(A + B) ÷ 2 = 11'-6" (3505)	50	48	41	33	29	24	22													
	(A + B) ÷ 2 = 11'-0" (3353)	50	48	41	33	29	24	22													
	(A + B) ÷ 2 = 10'-6" (3200)	50	48	41	33	29	24	22													
	(A + B) ÷ 2 = 10'-0" (3048)	50	48	41	33	29	24	22													
	(A + B) ÷ 2 = 9'-6" (2896)	50	48	41	33	29	24	22													
	(A + B) ÷ 2 = 9'-0" (2743)	50	48	41	33	29	24	22													
	(A + B) ÷ 2 = 8'-6" (2591)	50	48	41	33	29	24	22													
	(A + B) ÷ 2 = 8'-0" (2438)	50	48	41	33	29	24	22													
	(A + B) ÷ 2 = 7'-6" (2286)	50	48	41	33	29	24	22													
	(A + B) ÷ 2 = 7'-0" (2134)	50	48	41	33	29	24	22													
	(A + B) ÷ 2 = 6'-6" (1981)	50	48	41	33	29	25	22													
	(A + B) ÷ 2 = 6'-0" (1829)	50	48	41	33	29	25	23	20												
	(A + B) ÷ 2 = 5'-6" (1676)	50	48	41	33	30	26	24	21												
	(A + B) ÷ 2 = 5'-0" (1524)	50	48	41	34	31	27	24	22	20											
	(A + B) ÷ 2 = 4'-6" (1372)	50	48	42	36	32	28	26	23	22											
	(A + B) ÷ 2 = 4'-0" (1219)	50	49	43	37	34	30	28	25	23	21										
	(A + B) ÷ 2 = 3'-6" (1067)	50	50	47	40	37	33	31	28	26	24	23	20								
	(A + B) ÷ 2 = 3'-0" (914)	50	50	50	44	40	36	33	30	29	26	25	22	20							
(A + B) ÷ 2 = 2'-6" (762)	50	50	50	50	47	42	39	36	34	31	30	26	24	21	20						
(A + B) ÷ 2 = 2'-0" (610)	50	50	50	50	50	49	46	42	40	37	35	31	31	27	25	22					
(A + B) ÷ 2 = 1'-6" (457)	50	50	50	50	50	50	50	50	50	49	47	44	41	37	34	30	26				
C = (length of join)	4'-6" (1372) or less	5'-0" (1524)	5'-6" (1676)	6'-0" (1829)	6'-6" (1981)	7'-0" (2134)	7'-6" (2286)	8'-0" (2438)	8'-6" (2591)	9'-0" (2743)	9'-6" (2896)	10'-0" (3048)	10'-6" (3200)	11'-0" (3353)	11'-6" (3505)	12'-0" (3658)	12'-6" (3810)				

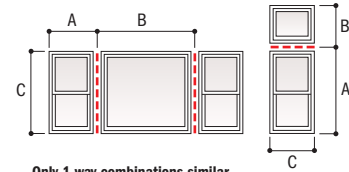

Only 1-way combinations similar to those shown above are allowed.



Vinyl Joining Material

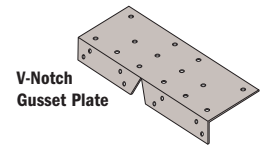

V-Notch Gusset Plate

Combination Designs

1-Way or 2-Way Steel Joining with V-Notch Gusset Plates 400 Series Tilt-Wash Double-Hung and Transom Windows

Average Adjacent Window Dimension	(A + B) ÷ 2 = 7'-6" (2286)	50	40	35	30	27	23	21												
	(A + B) ÷ 2 = 7'-0" (2134)	50	40	35	30	27	23	21												
	(A + B) ÷ 2 = 5'-6" (1676)	50	41	36	31	29	26	24	21	20										
	(A + B) ÷ 2 = 5'-0" (1524)	50	42	37	32	30	27	25	22	21										
	(A + B) ÷ 2 = 4'-6" (1372)	50	43	39	34	32	28	27	24	23	21									
	(A + B) ÷ 2 = 4'-0" (1219)	50	45	41	36	34	30	28	26	25	22	21								
	(A + B) ÷ 2 = 3'-6" (1067)	50	50	45	40	37	34	32	29	28	26	24	20							
	(A + B) ÷ 2 = 3'-0" (914)	50	50	50	44	41	37	35	32	30	28	26	22							
	(A + B) ÷ 2 = 2'-6" (762)	50	50	50	50	48	44	41	38	36	34	31	26	23						
	(A + B) ÷ 2 = 2'-0" (610)	50	50	50	50	50	50	48	44	41	38	36	34	30	24	21				
C = (length of join)	5'-6" (1676) or less	6'-0" (1829)	6'-6" (1981)	7'-0" (2134)	7'-6" (2286)	8'-0" (2438)	8'-6" (2591)	9'-0" (2743)	9'-6" (2896)	10'-0" (3048)	10'-6" (3200)	11'-0" (3353)	11'-6" (3505)	12'-0" (3658)	12'-6" (3810)					

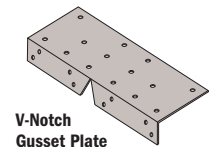
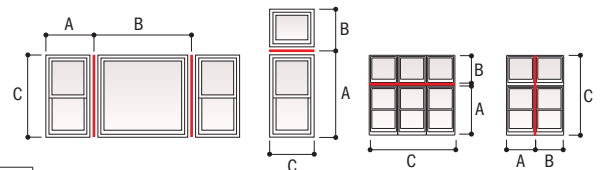

V-Notch Gusset Plate

3/16" (5) x 4" (102)
Steel Joining Material

- Numerical values in charts represent structural pressure only.
- Structural performance of any combination is only as high as the lowest structural performance of any individual unit or joining material in the combination.
- Andersen® products must be installed and anchored properly according to joining and installation guides to meet rated structural performance. Refer to product joining and installation instructions at andersenwindows.com.
- Dimensions in parentheses are in millimeters.

400 SERIES WINDOWS WITH TRIPLE-PANE GLASS



1-Way LVL Joining

400 Series Tilt-Wash Double-Hung and Transom Windows

4 9/16" (116) Minimum Wall Depth	Average Adjacent Window Dimension	(A + B) ÷ 2 = 6'-0" (1829)	50	50	50	50	40	32
		(A + B) ÷ 2 = 5'-6" (1676)	50	50	50	50	42	33
		(A + B) ÷ 2 = 5'-0" (1524)	50	50	50	50	43	35
		(A + B) ÷ 2 = 4'-6" (1372)	50	50	50	50	46	38
		(A + B) ÷ 2 = 4'-0" (1219)	50	50	50	50	49	39
		(A + B) ÷ 2 = 3'-6" (1067)	50	50	50	50	50	44
		(A + B) ÷ 2 = 3'-0" (914)	50	50	50	50	50	48
		(A + B) ÷ 2 = 2'-6" (762)	50	50	50	50	50	50
		(A + B) ÷ 2 = 2'-0" (610)	50	50	50	50	50	50
		(A + B) ÷ 2 = 1'-6" (457)	50	50	50	50	50	50
		(A + B) ÷ 2 = 1'-0" (305)	50	50	50	50	50	50
		C = (length of join)	5'-6" (1676) or less	6'-0" (1829)	6'-6" (1981)	7'-0" (2134)	7'-6" (2286)	8'-0" (2438)

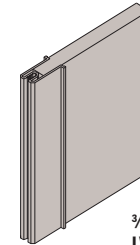
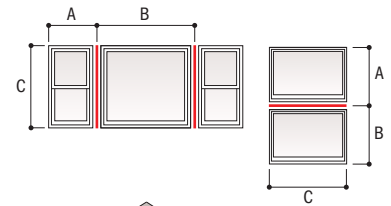

3/4" (19) x 5 3/4" (146)
LVL Joining Material
For 4 9/16" (116) jamb depths.

2-Way LVL Joining

400 Series Tilt-Wash Double-Hung and Transom Windows

6 9/16" (167) Minimum Wall Depth	Average Adjacent Window Dimension	(A + B) ÷ 2 = 10'-0" (3048)	50	50	50	50	48	44	37	31	24
		(A + B) ÷ 2 = 9'-6" (2896)	50	50	50	50	48	44	37	31	24
		(A + B) ÷ 2 = 9'-0" (2743)	50	50	50	50	48	44	37	31	24
		(A + B) ÷ 2 = 8'-6" (2591)	50	50	50	50	48	44	37	31	25
		(A + B) ÷ 2 = 8'-0" (2438)	50	50	50	50	48	44	37	31	25
		(A + B) ÷ 2 = 7'-6" (2286)	50	50	50	50	48	44	38	32	26
		(A + B) ÷ 2 = 7'-0" (2134)	50	50	50	50	49	45	39	33	26
		(A + B) ÷ 2 = 6'-6" (1981)	50	50	50	50	50	46	40	34	28
		(A + B) ÷ 2 = 6'-0" (1829)	50	50	50	50	50	47	41	35	29
		(A + B) ÷ 2 = 5'-6" (1676)	50	50	50	50	50	50	44	37	30
		(A + B) ÷ 2 = 5'-0" (1524)	50	50	50	50	50	50	46	39	32
		(A + B) ÷ 2 = 4'-6" (1372)	50	50	50	50	50	50	50	43	35
		(A + B) ÷ 2 = 4'-0" (1219)	50	50	50	50	50	50	50	46	38
		(A + B) ÷ 2 = 3'-6" (1067)	50	50	50	50	50	50	50	50	42
		(A + B) ÷ 2 = 3'-0" (914)	50	50	50	50	50	50	50	50	47
		(A + B) ÷ 2 = 2'-6" (762)	50	50	50	50	50	50	50	50	50
		(A + B) ÷ 2 = 2'-0" (610)	50	50	50	50	50	50	50	50	50
		(A + B) ÷ 2 = 1'-6" (457)	50	50	50	50	50	50	50	50	50
C = (length of join)	6'-0" (1829) or less	6'-6" (1981)	7'-0" (2134)	7'-6" (2286)	8'-0" (2438)	8'-6" (2591)	9'-0" (2743)	9'-6" (2896)	10'-0" (3048)		

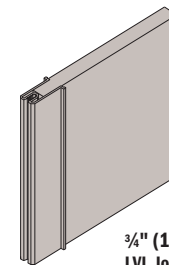
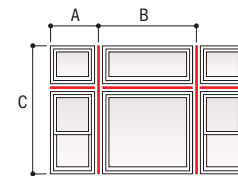

3/4" (19) x 7 3/4" (197)
LVL Joining Material
For 6 9/16" (167) jamb depths.

2-way joining must be assembled on the job site within the rough opening. When creating 2-way combinations for 6 9/16" (167) minimum wall thickness, 6 9/16" (167) LVL joining material is required.

- Numerical values in charts represent structural pressure only.
- Structural performance of any combination is only as high as the lowest structural performance of any individual unit or joining material in the combination.
- Andersen® products must be installed and anchored properly according to joining and installation guides to meet rated structural performance. Refer to product joining and installation instructions at andersenwindows.com.
- Dimensions in parentheses are in millimeters.

400 SERIES WINDOWS WITH TRIPLE-PANE GLASS



Altitude Limits for Products With Triple-Pane Glass

The chart below gives the altitude limit in feet for 400 Series products in this guide. If the installation of a given product is at an altitude greater than that shown in this chart, a capillary breather tube must be ordered. Be aware that the use of a capillary breather tube eliminates argon gas blend fill and will result in a lower thermal performance. For NFRC certified total unit performance on units with capillary breather tubes for higher altitude applications, see your Andersen supplier.

The use of triple-pane insulating glass without capillary breather tubes at altitudes higher than its rating will result in severe glass distortion, increased glass breakage potential and a risk of seal failure. Smaller windows are most affected by altitude changes. An increase in altitude results in a decrease in atmospheric pressure. A sealed insulating glass unit attempts to combat this change by increasing its volume to reduce its pressure. One way to increase its volume is by glass deflection. A smaller window is stiffer and does not deflect as much as a larger window; therefore, it cannot relieve the pressure as readily. Thus, the load applied to the glass is greater, resulting in a greater risk for breakage. Another way the window tries to increase its volume is by increasing the edge area; i.e., the seal area. The increased pressure applied to the edge seal load for a smaller window is therefore greater, increasing the chance for seal failure.

Andersen Product	3,000		4,000			5,000		6,000		7,000		8,000		9,000		10,000	
400 Series Casement Windows			CR12 CN12 C12 CW12 CR125 CN125 C125 CR13	CN13 C13 CR135 CN135 C135 CR14 CN14 CR145	CN145 CR15 CN15 CR155 CN155 CR16 CN16	CW125 CX125 CW13 CW135 C14 CW14 C145 CW145	C15 C155 C16	CX13 CX135 CX14 CX145 CW15 CX15 CW155 CW16		CX155 CX16	CXW13 CXW135 CXW14 CXW145						
400 Series Awning Windows			AR21 AR251 AR281 AR31 AR351 AR41 AR451 AR51 AR551	AR61 AN21 AN251 AN281 AN31 AN351 AN41 AN451 AN51	AN551 AN61 A21 A251 A281 A31 A351 AW21	A41 A451 A51 A551 A61 AW251 AW281 AW31	AW351 AW41 AW451 AX251	AW51 AW551 AW61 AX281 AX31 AX351 AX41 AX451	AX51 AXW281	AX551 AX61	AXW31 AXW351 AXW41 AXW451 AXW51 AXW551 A335 AP32V	AXW61 A3535 AP352V			AP42V		
400 Series Casement/Awning Picture								P3030 P3530 P4030 P4530 P5030 P5530 P3035 P3040	P3045 P3050 P3055	P6030 P5535 P6035 P3555 P3060 P3560	P3535 P4035 P4535 P5035 P3540 P3545 P3550	P4040 P4540 P5040 P5540 P6040 P4045 P4050 P4055	P4060	P4545 P5045 P5545 P6045 P4550 P5050 P5550 P6050			
400 Series Casement/Awning Transom	CTR15 CTR18 CTR20 CTR24 CTR28 CTR29	CTR30 PTR30 CTR34 CTR35 PTR35 CTR40	PTR40 CTR45 PTR45 CTR48 PTR50 PTR50	CTR51 CTR52 CTR55 PTR55 CTR511 CTR60	PTR60 CTR70												
			3,000														
400 Series Tilt-Wash Windows			TW18210 TW20210 TW24210 TW26210 TW28210 TW210210 TW30210 TW34210 TW38210	TW1832 TW2032 TW2432 TW2632 TW2832 TW21032 TW3032 TW3432 TW3832	TW1836 TW2036 TW2436 TW2636 TW2836 TW21036 TW3036 TW3436 TW18310	TW1842 TW1846 TW18410 TW1852 TW1856 TW18510 TW1862 TW1872	TW20310 TW24310 TW26310 TW28310 TW210310 TW30310 TW34310	TW2042 TW2442 TW2052 TW2642 TW2842 TW20510 TW2062	TW2446 TW2646 TW2846 TW21046 TW2462 TW2072 TW2472 TW2076 TW2476	TW2452 TW2456 TW24510 TW2462 TW2072 TW2472 TW2076 TW2476	TW2646 TW2846 TW21046 TW3046 TW3446 TW3846 TW26410 TW28410 TW210410	TW30410 TW34410 TW38410 TW2652 TW2656 TW26510 TW2662 TW2672 TW2676	TW2852 TW28510 TW3052 TW3452 TW3852 TW2856 TW21056 TW3056 TW3456	TW3856 TW28510 TW210510 TW2862 TW21062 TW2872 TW21072 TW2876 TW21076	TW30510 TW34510 TW38510 TW3062 TW3462 TW3862 TW3072 TW3472	TW3872 TW3076 TW3476 TW3876	
			3,000		4,000		5,000		6,000		7,000						
400 Series Tilt-Wash Transom Windows	TWT1810 TWT2010 TWT2410 TWT2610 TWT2810 TWT21010 TWT3010 TWT3410 TWT3810 TWT31010	TWT4210 TWT41010 TWT5610 TWT6210	TWT1815 TWT2015 TWT2415 TWT2615 TWT2815 TWT21015 TWT3015 TWT3415 TWT3815 TWT31015	TWT4215 TWT41015 TWT5615 TWT6215	TWT1817 TWT2017 TWT2417 TWT2617 TWT2817 TWT21017 TWT3017 TWT3417 TWT3817 TWT31017	TWT4217 TWT41017 TWT5617 TWT6217 TWT18111 TWT18121 TWT1821 TWT1823 TWT1827 TWT1831 TWT31017	TWT20111 TWT24111 TWT26111 TWT28111 TWT210111 TWT30111 TWT34111 TWT38111 TWT2021 TWT2421	TWT2621 TWT2821 TWT21021 TWT3021 TWT3421 TWT3821 TWT31021 TWT31023 TWT2027 TWT2031	TWT310111 TWT42111 TWT410111 TWT56111 TWT62111 TWT31023 TWT2423 TWT4223 TWT2623 TWT2823	TWT21023 TWT3023 TWT3423 TWT3823 TWT31023 TWT4223 TWT2427 TWT2431	TWT4221 TWT41021 TWT5621 TWT6221 TWT41023 TWT5623 TWT2627 TWT2631	TWT2827 TWT21027 TWT3027 TWT3427 TWT3827 TWT31027 TWT4227 TWT41027	TWT2831 TWT21031	TWT3031 TWT3431 TWT3831 TWT31031 TWT4231			
400 Series Circle & Oval Windows			CIR20 OVL1824						CIR24			CIR30 OVL3048					
400 Series Quarter Circle, Half Circle & Elliptical Windows			CTC1 CTCW1 CTCX1 CTCXW1	CTN20 CTN24 CTN28 CTN30	CTN34 ET6 ET8	CTQC1 CTC2		CTQW1 CTCW2 CTQX1		CTCX2 CTC3 CTN30-2							

* Deflection of glass will occur on units with larger glass areas. If interior/exterior grilles are used on double-hung windows at higher altitudes without capillary breather tubes, some interference may occur, affecting operation.

Product Performance

400 SERIES WINDOWS WITH TRIPLE-PANE GLASS



PERFORMANCE STANDARDS

The Window and Door Manufacturers Association (WDMA), the American Architectural Manufacturers Association (AAMA) and the Canadian Standards Association (CSA) jointly release the North American Fenestration Standard/Specification for Windows, Doors and Skylights (NAFS). NAFS is also referred to as AAMA/WDMA/CSA 101/I.S.2/A440, which is how the International Code Council (ICC) lists this standard in the International Residential Code (IRC) and International Building Code (IBC) as the means to indicate the window, door or skylights design pressure rating used to determine compliance to the job site design pressure requirements.

A product only achieves a "Performance Grade" or "PG" rating when it complies with all of the NAFS performance requirements such as ease of operation, air infiltration resistance, resistance to water penetration and resistance to forced entry, etc. A "Design Pressure Rating" or "DP" rating only depicts the design and structural load performance.

Performance Classes

The NAFS Standard/Specification defines requirements for four performance classes. Performance classes are designated R, LC, CW and AW. This classification system provides for several levels of performance. Product selection is always based on the performance and building code requirements of the particular project.

Elements of Performance Grade (PG) Designations

In order to qualify for a given performance grade (PG), test specimens need to pass all required performance tests for the following, in addition to all required auxiliary (durability) and applicable material/component tests (not shown here) for the applicable product type and desired performance class:

- (a) Operating force (if applicable):** Maximum operating force varies by product type and performance class.
- (b) Air leakage resistance:** Tested in accordance with ASTM E283 at a test pressure of 1.57 psf. Allowable air infiltration for R, LC and CW class designations is 0.3 cubic feet per minute per square foot of frame (cfm/ft²).
- (c) Water penetration resistance:** Tested in accordance with ASTM E547 with the specified test pressure applied per NAFS. Test consists of four cycles. Each cycle consists of five minutes with pressure applied and one minute with the pressure released, during which the water spray is continuously applied. Water spray shall be uniformly applied at a constant rate of 5 U.S. gal/ft² · hr.
- (d) Uniform load deflection test:** Tested in accordance with ASTM E330 for both positive and negative pressure (pressure defined by NAFS) with the load maintained for a period of 10 seconds. The test specimen shall be evaluated for deflection during each load for permanent damage after each load and for any effects on the normal operation of the specimen. *Starting with the 2008 version of NAFS, design pressure (DP) will only represent the "uniform load deflection test."*
- (e) Uniform load structural test:** Tested in accordance with ASTM E330 for both positive and negative pressure (pressure defined by NAFS) with the load maintained for a period of 10 seconds. After loads are removed, there shall be no permanent deformation in excess of 0.4% of its span and no damage to the unit, which would make it inoperable.
- (f) Forced-entry resistance (if applicable):** Tested in accordance with ASTM F588 (windows), F476 (swinging doors) and F842 (sliding doors) at a performance level 10 rating.

Performance Grades (PG) and Corresponding Test Pressures (psf)

Performance Class/ Performance Grade		Air Infiltration Test Pressure		Maximum Allowable Air Infiltration/ Exfiltration Rate		Water Penetration Resistance Test Pressure		Design Pressure		Structural Test Pressure	
R	LC	Pa	psf	L/s·m ²	cfm/ft ²	Pa	psf	Pa	psf	Pa	psf
15	-	75	1.57	1.5	0.30	140	2.92	720	15.04	1080	22.56
20	-	75	1.57	1.5	0.30	150	3.13	960	20.05	1440	30.08
25	25	75	1.57	1.5	0.30	180	3.76	1200	25.06	1800	37.59
30	30	75	1.57	1.5	0.30	220	4.59	1440	30.08	2160	45.11
35	35	75	1.57	1.5	0.30	260	5.43	1680	35.09	2520	52.63
40	40	75	1.57	1.5	0.30	290	6.06	1920	40.10	2880	60.15
45	45	75	1.57	1.5	0.30	330	6.89	2160	45.11	3240	67.67
50	50	75	1.57	1.5	0.30	360	7.52	2400	50.13	3600	75.19
55	55	75	1.57	1.5	0.30	400	8.35	2640	55.14	3960	82.71
60	60	75	1.57	1.5	0.30	440	9.19	2880	60.15	4320	90.23
65	65	75	1.57	1.5	0.30	470	9.82	3120	65.16	4680	97.74
70	70	75	1.57	1.5	0.30	510	10.65	3360	70.18	5040	105.26
75	75	75	1.57	1.5	0.30	540	11.28	3600	75.19	5400	112.78
80	80	75	1.57	1.5	0.30	580	12.11	3840	80.20	5760	120.30
85	85	75	1.57	1.5	0.30	620	12.94	4080	85.21	6120	127.82
90	90	75	1.57	1.5	0.30	660	13.78	4320	90.23	6480	135.34
95	95	75	1.57	1.5	0.30	682	14.25	4560	95.24	6840	142.86
100	100	75	1.57	1.5	0.30	718	15.00	4800	100.25	7200	150.38

HALLMARK CERTIFICATION

The Window and Door Manufacturers Association (WDMA)-sponsored Hallmark Certification Program provides manufacturers with certification to the AAMA/WDMA/CSA 101/I.S.2/A440 Standard and is designed to provide builders, architects, specifiers and consumers with an easily recognizable means of identifying products that have been manufactured and tested in accordance with NAFS (AAMA/WDMA/CSA 101/I.S.2/A440) industry standards and other applicable performance standards. Conformance is determined by periodic in-plant inspections by a third-party administrator. Inspections include auditing licensee quality control procedures and processes, and a review to confirm products are manufactured in accordance with the appropriate performance standards. Periodic testing of representative product constructions and components by an independent testing laboratory is also required. When all of the program requirements are met, the licensee is authorized to use the WDMA Hallmark registered logo on their certification label as a means of identifying products and their performance ratings.

Products successfully obtaining Hallmark Certification will be labeled with a three-part code, which includes performance class, performance grade and size tested. In addition to this mandatory requirement, you are allowed to list the design pressure on a separate line.

	Andersen Corporation 400 SERIES CASEMENT WINDOW Manufacturer stipulates certification as indicated below.					
	<table border="1"> <thead> <tr> <th>STANDARD</th> <th>RATING</th> </tr> </thead> <tbody> <tr> <td>AAMA/WDMA/CSA 101/I.S.2/A440-11</td> <td>Class LC⁽¹⁾ - PG50⁽²⁾ - Size Tested 56 x 71.8 in.⁽³⁾ DP+50/-50⁽⁴⁾</td> </tr> <tr> <td>AAMA/WDMA/CSA 101/I.S.2/A440-08</td> <td>Class LC⁽¹⁾ - PG50⁽²⁾ - Size Tested 56 x 71.8 in.⁽³⁾ DP+50/-50⁽⁴⁾</td> </tr> </tbody> </table>	STANDARD	RATING	AAMA/WDMA/CSA 101/I.S.2/A440-11	Class LC ⁽¹⁾ - PG50 ⁽²⁾ - Size Tested 56 x 71.8 in. ⁽³⁾ DP+50/-50 ⁽⁴⁾	AAMA/WDMA/CSA 101/I.S.2/A440-08
STANDARD	RATING					
AAMA/WDMA/CSA 101/I.S.2/A440-11	Class LC ⁽¹⁾ - PG50 ⁽²⁾ - Size Tested 56 x 71.8 in. ⁽³⁾ DP+50/-50 ⁽⁴⁾					
AAMA/WDMA/CSA 101/I.S.2/A440-08	Class LC ⁽¹⁾ - PG50 ⁽²⁾ - Size Tested 56 x 71.8 in. ⁽³⁾ DP+50/-50 ⁽⁴⁾					

- (1) - Performance Class
- (2) - Performance Grade
- (3) - Size Tested
- (4) - Design Pressure

In the example above, the performance class is LC, the performance grade (PG) is 50 pounds per square foot (psf) and the size tested is 56" x 71.8". What this means to the specifier is, based on the performance grade chart, the laboratory-tested air infiltration was less than 0.3 cfm/ft² (test pressure is always 1.57 psf and the allowable airflow is 0.3 cfm/ft²), the product tested successfully resisted a laboratory water penetration test at a test pressure of 7.5 psf, the product tested successfully withstood a laboratory positive test pressure of 75 psf and a laboratory negative test pressure of 75 psf, and the product tested passed the laboratory requirements for operational force and forced-entry resistance. Based on this test, all products of the same design that are smaller than the tested size can be labeled with this product performance rating.

IMPORTANT

Building codes prescribe design pressure based on a variety of criteria (i.e., windspeed zone, building height, building type, job site exposure, etc.). Design pressures derived from Performance Grade (PG) test requirements should be used to determine compliance to building code required design pressures. Structural test pressures, which are tested at 1.5 times the design pressure, should not be used for determining design pressure code compliance. In the example above, a PG 50 performance grade rating, which passes a 50 psf design pressure, should be used for determining code compliance, not the structural test pressure of 75 psf.

If you need further details about how Andersen® products perform to this standard, contact your Andersen supplier.

If you need further information about the AAMA/WDMA/CSA 101/I.S.2/A440 standard or the Hallmark Certification Program, please contact: WDMA, 2001 K Street NW, 3rd Floor North, Washington, D.C. 20006. Phone: 202-367-1157 Website: wdma.com

Where designated, Andersen products are tested, certified and labeled to the requirements of the Hallmark Certification Program. Actual performance may vary based on variations in manufacturing, shipping, installation, environmental conditions and conditions of use.

400 SERIES WINDOWS WITH TRIPLE-PANE GLASS



Performance Grade and Air Infiltration Ratings for Products With Triple-Pane Glass

For current performance information, please visit andersenwindows.com.

Andersen® 400 Series Product	Glass Construction	AAMA/WDMA/CSA 101/I.S.2/A440 Performance Grade (PG)	+/- Corresponding Design Pressure (DP)	Air Infiltration CFM/FT ²
Casement Windows				
Single Stationary (CXW145, CX155, CW16 and smaller)	Triple-Pane	Class LC-PG50 Size Tested 35.9" x 71.9"	50/50	< 0.2
Single Venting (CX155 and smaller)	Triple-Pane	Class LC-PG40 Size Tested 35.9" x 71.9"	40/40	< 0.2
Single Venting (CW16 and smaller)	Triple-Pane	Class LC-PG50 Size Tested 59.5" x 71.9"	50/50	< 0.2
Single Venting (CXW145 and smaller)	Triple-Pane	Class LC-PG50 Size Tested 71.8" x 52.9"	50/50	< 0.2
Single Venting (CX15 and smaller)	Triple-Pane	Class LC-PG50 Size Tested 62.8" x 59.9"	50/50	< 0.2
Twin Stationary & Venting (CXW245 and smaller)	Triple-Pane	Class LC-PG50 Size Tested 71.8" x 52.9"	50/50	< 0.2
Twin Stationary & Venting (CX25 and smaller)	Triple-Pane	Class LC-PG50 Size Tested 62.8" x 59.9"	50/50	< 0.2
Twin Stationary & Venting (CW26 and smaller)	Triple-Pane	Class LC-PG50 Size Tested 59.5" x 71.9"	50/50	< 0.2
Twin Stationary & Venting (CW35 and smaller)	Triple-Pane	Class LC-PG40 Size Tested 84.8" x 59.9"	40/40	< 0.2
Twin Stationary & Venting (C35 and smaller)	Triple-Pane	Class LC-PG50 Size Tested 71.5" x 59.9"	50/50	< 0.2
Casement/Awning Picture Windows	Triple-Pane	Class LC-PG50 Size Tested 71.9" x 59.9"	50/50	< 0.2
Casement/Awning Transom Windows	Triple-Pane	Class LC-PG70 Size Tested 84.6" x 12"	70/75	< 0.2
Awning Windows				
Single Stationary (AXW451, AX551, AW61 and smaller)	Triple-Pane	Class LC-PG50 Size Tested 35.9" x 71.9"	50/50	< 0.2
Single Venting (AXW451 and smaller)	Triple-Pane	Class LC-PG35 Size Tested 59.9" x 35.9"	35/35	< 0.2
Single Venting (AX551, AW61 and smaller)	Triple-Pane	Class LC-PG35 Size Tested 71.8" x 31.5"	35/35	< 0.2
Twin Venting (AXW231 and smaller)	Triple-Pane	Class LC-PG35 Size Tested 71.8" x 35.9"	35/35	< 0.2
Triple Venting (AX3251 and smaller)	Triple-Pane	Class LC-PG35 Size Tested 84.7" x 31.5"	35/35	< 0.2
Triple Venting (A313 and smaller)	Triple-Pane	Class LC-PG35 Size Tested 35.9" x 71.8"	35/35	< 0.2
Picture Venting (PA4060 and smaller)	Triple-Pane	Class LC-PG35 Size Tested 48.0" x 71.7"	35/35	< 0.2
Tilt-Wash Windows				
Double-Hung (3862 and smaller)	Triple-Pane	Class LC-PG40 Size Tested 45.6" x 76.9"	40/40	< 0.2
Double-Hung (cottage & reverse cottage sash, 3856 and smaller)	Triple-Pane	Class LC-PG40 Size Tested 45" x 68"	40/40	< 0.2
Double-Hung** (3876 and smaller)	Triple-Pane	Class LC-PG30 Size Tested 45.5" x 92.9"	30/35	< 0.2
Double-Hung** (cottage & reverse cottage sash, greater than 1856 to 3852)	Triple-Pane	Class LC-PG30 Size Tested 45.5" x 92.9"	30/35	< 0.2
Transom (6231 and smaller)	Triple-Pane	Class LC-PG50 Size Tested 75.4" x 39.4"	50/50	< 0.2
Specialty Windows				
Casement/Awning Half Circle	Triple-Pane	Class LC-PG50 Size Tested 71.9" x 59.9"	50/50	< 0.2
Tilt-Wash Double-Hung Half Circle	Triple-Pane	Class LC-PG50 Size Tested 75.4" x 40.0"	50/50	< 0.2
Quarter Circle, Circle & Oval	Triple-Pane	Class LC-PG50 Size Tested 71.9" x 59.9"	50/50	< 0.2
Elliptical	Triple-Pane	Class LC-PG70 Size Tested 95.3" x 21.0"	70/70	< 0.2
Complementary Specialty Windows (direct-set, fixed)	Triple-Pane	Class LC-PG50 Size Tested 125.0" x 84.0"	50/50	< 0.2

• Performance Grade (PG) ratings may vary from tested performance rating for larger or smaller units of a particular type.
 • This data is accurate as of April 2025. Due to ongoing product changes, updated test results or new industry standards, this data may change over time.
 • Where designated, Andersen products are certified and labeled to the requirements of the Hallmark Certification Program. Actual performance may vary based on variations in manufacturing, shipping, installation, environmental conditions and conditions of use.
 • Contact your Andersen supplier for more information.
 • Window size tested is an integral twin or triple window, and qualifies the window listed under the same test.
 • **Equal sash windows greater than 6'-4 7/8" (1953) in height and cottage and reverse cottage sash windows greater than 7'-8 7/8" (2359) in height have interior and exterior brackets. Interior brackets, located on each side of the meeting rail, must be flipped up for proper product performance.

Product Performance

400 SERIES WINDOWS WITH TRIPLE-PANE GLASS



Sound Transmission Ratings for Products With Triple-Pane Glass

For current performance information, please visit andersenwindows.com.

Andersen® 400 Series Product	Glass Construction	Sound Transmission Class (STC)	Outdoor/Indoor Transmission Class (OITC)
Caseament Windows	Triple-Pane	29	25
Awning Windows	Triple-Pane	29	24
Caseament/Awning Picture Windows	Triple-Pane	30	25
Tilt-Wash Double-Hung Windows			
Double-Hung	Triple-Pane	27	23
Transom	Triple-Pane	†	†
Specialty Windows	Triple-Pane	30	25
Complementary Specialty Windows	Triple-Pane	†	†

• Sound Transmission Class (STC) and Outdoor/Indoor Transmission Class (OITC) ratings are for individual units based on independent tests and represent entire unit.
 • This data is accurate as of April 2025. Due to ongoing product changes, updated test results or new industry standards, this data may change over time.
 • Contact your Andersen supplier for more information.
 †Data not available.

Center of Glass Performance for Products With Triple-Pane Glass

For current performance information, please visit andersenwindows.com.

Andersen® 400 Series Product	VT ¹	SC ²	SHGC ³	RHG ⁴	Fading		%RH @ center ⁷	IGST ⁸
					Tuv ⁵	Tdw ⁶		
Low-E⁴								
Caseament, Awning, Casement/Awning Transom, Quarter Circle, Half Circle, Circle, Oval and Elliptical Windows	66%	0.44	0.38	92	14%	30%	64%	57°F
Caseament/Awning Picture Windows	66%	0.44	0.38	91	14%	30%	67%	58°F
Tilt-Wash Double-Hung and Tilt-Wash Transom Windows	67%	0.45	0.39	93	15%	31%	62%	56°F
Low-E⁴ Enhanced								
Caseament, Awning, Casement/Awning Transom, Quarter Circle, Half Circle, Circle, Oval and Elliptical Windows	63%	0.42	0.37	86	8%	24%	71%	60°F
Caseament/Awning Picture Windows	63%	0.42	0.36	86	8%	24%	74%	61°F
Tilt-Wash Double-Hung and Tilt-Wash Transom Windows	64%	0.43	0.37	88	8%	25%	69%	59°F
Low-E⁴ Enhanced With HeatLock® Technology								
Caseament, Awning, Casement/Awning Transom, Quarter Circle, Half Circle, Circle, Oval and Elliptical Windows	62%	0.41	0.36	84	8%	23%	54%	53°F
Caseament/Awning Picture Windows	62%	0.41	0.36	84	8%	23%	57%	54°F
Tilt-Wash Double-Hung and Tilt-Wash Transom Windows	63%	0.42	0.36	85	8%	24%	51%	51°F
Low-E⁴ SmartSun								
Caseament, Awning, Casement/Awning Transom, Quarter Circle, Half Circle, Circle, Oval and Elliptical Windows	59%	0.29	0.25	62	4%	19%	65%	58°F
Caseament/Awning Picture Windows	59%	0.29	0.25	61	4%	19%	68%	59°F
Tilt-Wash Double-Hung and Tilt-Wash Transom Windows	60%	0.30	0.26	62	5%	20%	63%	57°F
Low-E⁴ SmartSun™ Enhanced								
Caseament, Awning, Casement/Awning Transom, Quarter Circle, Half Circle, Circle, Oval and Elliptical Windows	57%	0.28	0.24	58	2%	16%	71%	60°F
Caseament/Awning Picture Windows	57%	0.28	0.24	57	2%	16%	74%	62°F
Tilt-Wash Double-Hung and Tilt-Wash Transom Windows	58%	0.28	0.24	59	3%	17%	69%	59°F
Low-E⁴ SmartSun Enhanced With HeatLock Technology								
Caseament, Awning, Casement/Awning Transom, Quarter Circle, Half Circle, Circle, Oval and Elliptical Windows	56%	0.27	0.24	57	2%	16%	54%	53°F
Caseament/Awning Picture Windows	56%	0.27	0.24	56	2%	16%	58%	55°F
Tilt-Wash Double-Hung and Tilt-Wash Transom Windows	56%	0.28	0.24	57	3%	16%	52%	52°F
Low-E⁴ PassiveSun® Enhanced With HeatLock Technology								
Caseament, Awning, Casement/Awning Transom, Quarter Circle, Half Circle, Circle, Oval and Elliptical Windows	68%	0.61	0.53	124	13%	28%	53%	52°F
Caseament/Awning Picture Windows	68%	0.61	0.53	124	13%	28%	57%	54°F
Tilt-Wash Double-Hung and Tilt-Wash Transom Windows	69%	0.62	0.54	126	14%	29%	51%	51°F

• Based on NFRC testing/simulation conditions using Windows v7.8.74.0 and NFRC validated spectral data. 0°F outside temperature, 70°F inside temperature and a 12 mph wind. 1) Visible Transmittance (VT) measures how much light comes through the glass. The higher the value, from 0 to 1, the more daylight the glass lets in. Visible Transmittance is measured over the 380 to 760 nanometer portion of the solar spectrum. 2) Shading Coefficient (SC) defines the amount of heat gain through the glass compared to a single light of clear 1/8" (3) glass. 3) Solar Heat Gain Coefficient (SHGC) defines the fraction of solar radiation admitted through the glass directly transmitted, as well as absorbed and subsequently released inward. The lower the value, the less heat is transmitted through the product. 4) Relative Heat Gain (RHG) is the amount of heat gain through a glazing incorporating U-Factor and Solar Heat Gain Coefficient. 5) Transmission Ultra-Violet Energy (Tuv). The transmission of short-wave energy in the 300-380 nanometer portion of the solar spectrum. The energy can cause fabric fading. 6) Transmission Damage Function (Tdw). The transmission of UV and visible light energy in the 300-600 nanometer portion of the solar spectrum. The value includes both the UV and visible light energy that can cause fabric fading. This rating has also been referred to as the Krochmann Damage Function. This rating better predicts fading potential than UV transmission alone. The lower the Damage Function rating, the less transmission of short-wave energy through the glass that can potentially cause fabric fading. Fabric type is also a key component of fading potential. 7) Percent relative humidity before condensation occurs at the center of glass, taken using center of glass temperature. 8) Inside glass surface temperatures are taken at the center of glass.

• This data is accurate as of April 2025. Due to ongoing product changes, updated test results or new industry standards, this data may change over time. Contact your Andersen supplier for current performance information or upgrade options.

• Contact your Andersen supplier for center of glass performance data on windows with patterned glass, tempered glass and products ordered with capillary breather tubes.

400 SERIES WINDOWS WITH TRIPLE-PANE GLASS



NFRC Certified Total Unit Performance for Products With Triple-Pane Glass

This information is for reference only. Performance values vary based on unit size, configurations and options. Contact your Andersen supplier for specific unit data.

Andersen® Product	High-Performance Triple-Pane Glass Type	U-Factor ¹	SHGC ²	VT ³	
400 Series Casement Windows AND-N-1	Low-E4*	Without Grilles	0.26	0.29	0.49
		Simulated Divided Light Grilles	0.26	0.27	0.45
		Finelight™ Grilles	0.26	0.27	0.45
		Full Divided Light Grilles	-	-	-
	Low-E4 Enhanced	Without Grilles	0.22	0.29	0.47
		Simulated Divided Light Grilles	0.22	0.26	0.43
		Finelight Grilles	0.22	0.26	0.43
		Full Divided Light Grilles	-	-	-
	Low-E4 Enhanced w/HeatLock®	Without Grilles	0.20	0.27	0.46
		Simulated Divided Light Grilles	0.20	0.25	0.42
		Finelight Grilles	0.20	0.25	0.42
		Full Divided Light Grilles	-	-	-
	Low-E4 SmartSun™	Without Grilles	0.25	0.20	0.44
		Simulated Divided Light Grilles	0.25	0.18	0.40
		Finelight Grilles	0.26	0.18	0.40
		Full Divided Light Grilles	-	-	-
	Low-E4 SmartSun Enhanced	Without Grilles	0.22	0.19	0.43
		Simulated Divided Light Grilles	0.22	0.18	0.39
		Finelight Grilles	0.22	0.18	0.39
		Full Divided Light Grilles	-	-	-
	Low-E4 SmartSun Enhanced w/HeatLock	Without Grilles	0.20	0.18	0.42
		Simulated Divided Light Grilles	0.20	0.17	0.38
		Finelight Grilles	0.20	0.17	0.38
		Full Divided Light Grilles	-	-	-
Low-E4 PassiveSun™ Enhanced w/HeatLock	Without Grilles	0.20	0.40	0.51	
	Simulated Divided Light Grilles	0.20	0.37	0.47	
	Finelight Grilles	0.20	0.37	0.47	
	Full Divided Light Grilles	-	-	-	
400 Series Awning Windows AND-N-2	Low-E4*	Without Grilles	0.26	0.29	0.49
		Simulated Divided Light Grilles	0.26	0.27	0.45
		Finelight™ Grilles	0.26	0.27	0.45
		Full Divided Light Grilles	-	-	-
	Low-E4 Enhanced	Without Grilles	0.22	0.29	0.47
		Simulated Divided Light Grilles	0.22	0.26	0.43
		Finelight Grilles	0.22	0.26	0.43
		Full Divided Light Grilles	-	-	-
	Low-E4 Enhanced w/HeatLock®	Without Grilles	0.20	0.27	0.46
		Simulated Divided Light Grilles	0.20	0.25	0.42
		Finelight Grilles	0.20	0.25	0.42
		Full Divided Light Grilles	-	-	-
	Low-E4 SmartSun™	Without Grilles	0.25	0.20	0.44
		Simulated Divided Light Grilles	0.25	0.18	0.40
		Finelight Grilles	0.26	0.18	0.40
		Full Divided Light Grilles	-	-	-
	Low-E4 SmartSun Enhanced	Without Grilles	0.22	0.19	0.43
		Simulated Divided Light Grilles	0.22	0.18	0.39
		Finelight Grilles	0.22	0.18	0.39
		Full Divided Light Grilles	-	-	-
	Low-E4 SmartSun Enhanced w/HeatLock	Without Grilles	0.20	0.18	0.42
		Simulated Divided Light Grilles	0.20	0.17	0.38
		Finelight Grilles	0.20	0.17	0.38
		Full Divided Light Grilles	-	-	-
Low-E4 PassiveSun™ Enhanced w/HeatLock	Without Grilles	0.20	0.40	0.51	
	Simulated Divided Light Grilles	0.20	0.37	0.46	
	Finelight Grilles	0.20	0.37	0.46	
	Full Divided Light Grilles	-	-	-	

Andersen® Product	High-Performance Triple-Pane Glass Type	U-Factor ¹	SHGC ²	VT ³	
400 Series Casement/Awning Picture Windows AND-N-54	Low-E4*	Without Grilles	0.22	0.32	0.54
		Simulated Divided Light Grilles	0.22	0.29	0.49
		Finelight™ Grilles	0.22	0.29	0.49
		Full Divided Light Grilles	-	-	-
	Low-E4 Enhanced	Without Grilles	0.18	0.31	0.52
		Simulated Divided Light Grilles	0.18	0.28	0.47
		Finelight Grilles	0.18	0.28	0.47
		Full Divided Light Grilles	-	-	-
	Low-E4 Enhanced w/HeatLock®	Without Grilles	0.16	0.30	0.51
		Simulated Divided Light Grilles	0.16	0.27	0.46
		Finelight Grilles	0.16	0.27	0.46
		Full Divided Light Grilles	-	-	-
	Low-E4 SmartSun™	Without Grilles	0.21	0.21	0.49
		Simulated Divided Light Grilles	0.21	0.19	0.44
		Finelight Grilles	0.22	0.19	0.44
		Full Divided Light Grilles	-	-	-
	Low-E4 SmartSun Enhanced	Without Grilles	0.17	0.21	0.47
		Simulated Divided Light Grilles	0.17	0.19	0.42
		Finelight Grilles	0.18	0.19	0.42
		Full Divided Light Grilles	-	-	-
	Low-E4 SmartSun Enhanced w/HeatLock	Without Grilles	0.16	0.20	0.46
		Simulated Divided Light Grilles	0.16	0.18	0.41
		Finelight Grilles	0.16	0.18	0.41
		Full Divided Light Grilles	-	-	-
Low-E4 PassiveSun™ Enhanced w/HeatLock	Without Grilles	0.16	0.44	0.57	
	Simulated Divided Light Grilles	0.16	0.40	0.51	
	Finelight Grilles	0.16	0.40	0.51	
	Full Divided Light Grilles	-	-	-	
400 Series Casement/Awning Transom Windows AND-N-54	Low-E4*	Without Grilles	0.24	0.32	0.54
		Simulated Divided Light Grilles	0.24	0.29	0.49
		Finelight™ Grilles	0.24	0.29	0.49
		Full Divided Light Grilles	-	-	-
	Low-E4 Enhanced	Without Grilles	0.19	0.31	0.52
		Simulated Divided Light Grilles	0.19	0.28	0.47
		Finelight Grilles	0.20	0.28	0.47
		Full Divided Light Grilles	-	-	-
	Low-E4 Enhanced w/HeatLock®	Without Grilles	0.17	0.30	0.51
		Simulated Divided Light Grilles	0.17	0.27	0.46
		Finelight Grilles	0.18	0.27	0.46
		Full Divided Light Grilles	-	-	-
	Low-E4 SmartSun™	Without Grilles	0.23	0.21	0.49
		Simulated Divided Light Grilles	0.23	0.19	0.44
		Finelight Grilles	0.24	0.19	0.44
		Full Divided Light Grilles	-	-	-
	Low-E4 SmartSun Enhanced	Without Grilles	0.19	0.21	0.47
		Simulated Divided Light Grilles	0.19	0.19	0.42
		Finelight Grilles	0.20	0.19	0.42
		Full Divided Light Grilles	-	-	-
	Low-E4 SmartSun Enhanced w/HeatLock	Without Grilles	0.17	0.20	0.46
		Simulated Divided Light Grilles	0.17	0.18	0.41
		Finelight Grilles	0.18	0.18	0.41
		Full Divided Light Grilles	-	-	-
Low-E4 PassiveSun™ Enhanced w/HeatLock	Without Grilles	0.18	0.44	0.57	
	Simulated Divided Light Grilles	0.18	0.40	0.51	
	Finelight Grilles	0.18	0.40	0.51	
	Full Divided Light Grilles	-	-	-	

continued on next page

Product Performance

*"Low-E4;" "Low-E4 SmartSun;" "Low-E4 PassiveSun" and "HeatLock" are Andersen trademarks for "Low-E" glass.
 1) U-Factor defines the amount of heat loss through the total unit in BTU/hr-ft²-°F. The lower the value, the less heat is lost through the entire product. Window values represent non-tempered glass. Use of tempered glass can increase U-Factor ratings. See andersenwindows.com/nfrc for specific performance values. 2) Solar Heat Gain Coefficient (SHGC) defines the fraction of solar radiation admitted through the glass directly transmitted, as well as absorbed and subsequently released inward. The lower the value, the less heat is transmitted through the product. 3) Visible Transmittance (VT) measures how much light comes through a product (glass and frame). The higher the value, from 0 to 1, the more daylight the product lets in over the product's total unit area. Visible Light Transmittance is measured over the 380 to 760 nanometer portion of the solar spectrum.
 • NFRC ratings are based on modeling by a third-party agency as validated by an independent test lab in compliance with NFRC program and procedural requirements.
 • This data is accurate as of April 2025. Due to ongoing product changes, updated test results, or new industry standards or requirements, this data may change over time. Ratings are for sizes specified by NFRC for testing and certification. Ratings may vary depending on use of tempered glass, different grille options, glass with capillary breather tubes for high altitudes, etc.
 • Values are for single units with given pane thickness and 3/4" (19 mm) grilles.

400 SERIES WINDOWS WITH TRIPLE-PANE GLASS



NFRC Certified Total Unit Performance for Products With Triple-Pane Glass (continued)

This information is for reference only. Performance values vary based on unit size, configurations and options. Contact your Andersen supplier for specific unit data.

Andersen® Product	High-Performance Triple-Pane Glass Type	U-Factor ¹	SHGC ²	VT ³	
400 Series Tilt-Wash Double-Hung Windows AND-N-24	Low-E4*	Without Grilles	0.28	0.29	0.49
		Simulated Divided Light Grilles	0.28	0.26	0.44
		Finelight™ Grilles	0.29	0.26	0.44
		Full Divided Light Grilles	-	-	-
	Low-E4 Enhanced	Without Grilles	0.25	0.28	0.47
		Simulated Divided Light Grilles	0.25	0.26	0.42
		Finelight Grilles	0.25	0.26	0.42
		Full Divided Light Grilles	-	-	-
	Low-E4 Enhanced w/HeatLock®	Without Grilles	0.22	0.27	0.46
		Simulated Divided Light Grilles	0.22	0.24	0.41
		Finelight Grilles	0.23	0.24	0.41
		Full Divided Light Grilles	-	-	-
	Low-E4 SmartSun™	Without Grilles	0.28	0.19	0.44
		Simulated Divided Light Grilles	0.28	0.17	0.39
		Finelight Grilles	0.28	0.17	0.39
		Full Divided Light Grilles	-	-	-
	Low-E4 SmartSun Enhanced	Without Grilles	0.24	0.19	0.43
		Simulated Divided Light Grilles	0.24	0.17	0.38
		Finelight Grilles	0.25	0.17	0.38
		Full Divided Light Grilles	-	-	-
	Low-E4 SmartSun Enhanced w/HeatLock	Without Grilles	0.22	0.18	0.42
		Simulated Divided Light Grilles	0.22	0.16	0.37
		Finelight Grilles	0.23	0.16	0.37
		Full Divided Light Grilles	-	-	-
PassiveSun™ Enhanced w/HeatLock	Without Grilles	0.23	0.40	0.51	
	Simulated Divided Light Grilles	0.23	0.36	0.45	
	Finelight Grilles	0.23	0.36	0.45	
	Full Divided Light Grilles	-	-	-	
400 Series Tilt-Wash Double-Hung Windows With Energy Performance Panel* AND-N-24	Low-E4*	Without Grilles	0.21	0.28	0.44
		Simulated Divided Light Grilles	0.21	0.25	0.39
		Finelight™ Grilles	0.21	0.25	0.39
		Full Divided Light Grilles	-	-	-
	Low-E4 Enhanced	Without Grilles	0.19	0.27	0.42
		Simulated Divided Light Grilles	0.19	0.24	0.37
		Finelight Grilles	0.19	0.24	0.37
		Full Divided Light Grilles	-	-	-
	Low-E4 Enhanced w/HeatLock®	Without Grilles	0.17	0.26	0.41
		Simulated Divided Light Grilles	0.17	0.23	0.37
		Finelight Grilles	0.17	0.23	0.37
		Full Divided Light Grilles	-	-	-
	Low-E4 SmartSun™	Without Grilles	0.21	0.20	0.40
		Simulated Divided Light Grilles	0.21	0.18	0.35
		Finelight Grilles	0.21	0.18	0.35
		Full Divided Light Grilles	-	-	-
	Low-E4 SmartSun Enhanced	Without Grilles	0.18	0.19	0.38
		Simulated Divided Light Grilles	0.18	0.17	0.34
		Finelight Grilles	0.19	0.17	0.34
		Full Divided Light Grilles	-	-	-
	Low-E4 SmartSun Enhanced w/HeatLock	Without Grilles	0.17	0.18	0.37
		Simulated Divided Light Grilles	0.17	0.17	0.33
		Finelight Grilles	0.17	0.17	0.33
		Full Divided Light Grilles	-	-	-
PassiveSun™ Enhanced w/HeatLock	Without Grilles	0.17	0.36	0.46	
	Simulated Divided Light Grilles	0.17	0.32	0.41	
	Finelight Grilles	0.17	0.32	0.41	
	Full Divided Light Grilles	-	-	-	

Andersen® Product	High-Performance Triple-Pane Glass Type	U-Factor ¹	SHGC ²	VT ³	
400 Series Tilt-Wash Transom Windows AND-N-76	Low-E4*	Without Grilles	0.25	0.30	0.51
		Simulated Divided Light Grilles	0.25	0.27	0.45
		Finelight™ Grilles	0.26	0.27	0.45
		Full Divided Light Grilles	-	-	-
	Low-E4 Enhanced	Without Grilles	0.21	0.29	0.49
		Simulated Divided Light Grilles	0.21	0.26	0.44
		Finelight Grilles	0.21	0.26	0.44
		Full Divided Light Grilles	-	-	-
	Low-E4 Enhanced w/HeatLock®	Without Grilles	0.19	0.28	0.48
		Simulated Divided Light Grilles	0.19	0.25	0.43
		Finelight Grilles	0.19	0.25	0.43
		Full Divided Light Grilles	-	-	-
	Low-E4 SmartSun™	Without Grilles	0.25	0.2	0.46
		Simulated Divided Light Grilles	0.25	0.18	0.41
		Finelight Grilles	0.25	0.18	0.41
		Full Divided Light Grilles	-	-	-
	Low-E4 SmartSun Enhanced	Without Grilles	0.21	0.19	0.44
		Simulated Divided Light Grilles	0.21	0.18	0.39
		Finelight Grilles	0.21	0.18	0.39
		Full Divided Light Grilles	-	-	-
	Low-E4 SmartSun Enhanced w/HeatLock	Without Grilles	0.19	0.19	0.43
		Simulated Divided Light Grilles	0.19	0.17	0.38
		Finelight Grilles	0.19	0.17	0.38
		Full Divided Light Grilles	-	-	-
PassiveSun™ Enhanced w/HeatLock	Without Grilles	0.19	0.42	0.53	
	Simulated Divided Light Grilles	0.19	0.37	0.47	
	Finelight Grilles	0.19	0.37	0.47	
	Full Divided Light Grilles	-	-	-	
400 Series Circle and Oval Windows AND-N-148	Low-E4*	Without Grilles	0.24	0.32	0.54
		Simulated Divided Light Grilles	0.24	0.29	0.48
		Finelight™ Grilles	0.24	0.29	0.48
		Full Divided Light Grilles	-	-	-
	Low-E4 Enhanced	Without Grilles	0.19	0.31	0.52
		Simulated Divided Light Grilles	0.19	0.28	0.47
		Finelight Grilles	0.20	0.28	0.47
		Full Divided Light Grilles	-	-	-
	Low-E4 Enhanced w/HeatLock®	Without Grilles	0.17	0.30	0.51
		Simulated Divided Light Grilles	0.17	0.27	0.46
		Finelight Grilles	0.18	0.27	0.46
		Full Divided Light Grilles	-	-	-
	Low-E4 SmartSun™	Without Grilles	0.23	0.21	0.49
		Simulated Divided Light Grilles	0.23	0.19	0.44
		Finelight Grilles	0.24	0.19	0.44
		Full Divided Light Grilles	-	-	-
	Low-E4 SmartSun Enhanced	Without Grilles	0.19	0.21	0.47
		Simulated Divided Light Grilles	0.19	0.19	0.42
		Finelight Grilles	0.19	0.19	0.42
		Full Divided Light Grilles	-	-	-
	Low-E4 SmartSun Enhanced w/HeatLock	Without Grilles	0.17	0.20	0.46
		Simulated Divided Light Grilles	0.17	0.18	0.41
		Finelight Grilles	0.17	0.18	0.41
		Full Divided Light Grilles	-	-	-
PassiveSun™ Enhanced w/HeatLock	Without Grilles	0.17	0.44	0.56	
	Simulated Divided Light Grilles	0.17	0.40	0.50	
	Finelight Grilles	0.18	0.40	0.50	
	Full Divided Light Grilles	-	-	-	

continued on next page

Product Performance

"Low-E4" "Low-E4 SmartSun™" "Low-E4 PassiveSun™" and "HeatLock™" are Andersen trademarks for "Low-E" glass.

1) U-Factor defines the amount of heat loss through the total unit in BTU/hr-ft²-°F. The lower the value, the less heat is lost through the entire product. Window values represent non-tempered glass. Use of tempered glass can increase U-Factor ratings. See andersenwindows.com/nfrc for specific performance values. 2) Solar Heat Gain Coefficient (SHGC) defines the fraction of solar radiation admitted through the glass directly transmitted, as well as absorbed and subsequently released inward. The lower the value, the less heat is transmitted through the product. 3) Visible Transmittance (VT) measures how much light comes through a product (glass and frame). The higher the value, from 0 to 1, the more daylight the product lets in over the product's total unit area. Visible Light Transmittance is measured over the 380 to 760 nanometer portion of the solar spectrum.

* NFRC ratings are based on modeling by a third-party agency as validated by an independent test lab in compliance with NFRC program and procedural requirements.

* This data is accurate as of April 2025. Due to ongoing product changes, updated test results, or new industry standards or requirements, this data may change over time. Ratings are for sizes specified by NFRC for testing and certification. Ratings may vary depending on use of tempered glass, different grille options, glass with capillary breather tubes for high altitudes, etc.

* Values are for single units with given pane thickness and 3/4" (19 mm) grilles.

* Factory applied.

400 SERIES WINDOWS WITH TRIPLE-PANE GLASS



NFRC Certified Total Unit Performance for Products With Triple-Pane Glass (continued)

This information is for reference only. Performance values vary based on unit size, configurations and options. Contact your Andersen supplier for specific unit data.

Andersen® Product	High-Performance Triple-Pane Glass Type	U-Factor ¹	SHGC ²	VT ³	
400 Series Double-Hung Half Circle (CTN) Windows AND-N-7	Low-E4*	Without Grilles	0.24	0.31	0.53
		Simulated Divided Light Grilles	0.24	0.28	0.47
		Finelight™ Grilles	0.24	0.28	0.47
		Full Divided Light Grilles	-	-	-
	Low-E4 Enhanced	Without Grilles	0.20	0.30	0.51
		Simulated Divided Light Grilles	0.20	0.27	0.45
		Finelight Grilles	0.20	0.27	0.45
		Full Divided Light Grilles	-	-	-
	Low-E4 Enhanced w/HeatLock®	Without Grilles	0.17	0.29	0.49
		Simulated Divided Light Grilles	0.17	0.26	0.44
		Finelight Grilles	0.18	0.26	0.44
		Full Divided Light Grilles	-	-	-
	Low-E4 SmartSun™	Without Grilles	0.23	0.21	0.47
		Simulated Divided Light Grilles	0.23	0.19	0.42
		Finelight Grilles	0.24	0.19	0.42
		Full Divided Light Grilles	-	-	-
	Low-E4 SmartSun Enhanced	Without Grilles	0.19	0.20	0.46
		Simulated Divided Light Grilles	0.19	0.18	0.41
		Finelight Grilles	0.20	0.18	0.41
		Full Divided Light Grilles	-	-	-
	Low-E4 SmartSun Enhanced w/HeatLock	Without Grilles	0.17	0.19	0.45
		Simulated Divided Light Grilles	0.17	0.18	0.40
		Finelight Grilles	0.18	0.18	0.40
		Full Divided Light Grilles	-	-	-
PassiveSun™ Enhanced w/HeatLock	Without Grilles	0.18	0.42	0.55	
	Simulated Divided Light Grilles	0.18	0.38	0.49	
	Finelight Grilles	0.18	0.38	0.49	
	Full Divided Light Grilles	-	-	-	
400 Series Quarter Circle and Casement/Awning Half Circle Windows AND-N-147	Low-E4*	Without Grilles	0.23	0.32	0.55
		Simulated Divided Light Grilles	0.23	0.29	0.49
		Finelight™ Grilles	0.24	0.29	0.49
		Full Divided Light Grilles	-	-	-
	Low-E4 Enhanced	Without Grilles	0.19	0.31	0.53
		Simulated Divided Light Grilles	0.19	0.28	0.47
		Finelight Grilles	0.20	0.28	0.47
		Full Divided Light Grilles	-	-	-
	Low-E4 Enhanced w/HeatLock®	Without Grilles	0.17	0.30	0.51
		Simulated Divided Light Grilles	0.17	0.27	0.46
		Finelight Grilles	0.18	0.27	0.46
		Full Divided Light Grilles	-	-	-
	Low-E4 SmartSun™	Without Grilles	0.23	0.21	0.49
		Simulated Divided Light Grilles	0.23	0.19	0.44
		Finelight Grilles	0.24	0.19	0.44
		Full Divided Light Grilles	-	-	-
	Low-E4 SmartSun Enhanced	Without Grilles	0.19	0.21	0.47
		Simulated Divided Light Grilles	0.19	0.19	0.42
		Finelight Grilles	0.19	0.19	0.42
		Full Divided Light Grilles	-	-	-
	Low-E4 SmartSun Enhanced w/HeatLock	Without Grilles	0.17	0.20	0.46
		Simulated Divided Light Grilles	0.17	0.18	0.41
		Finelight Grilles	0.17	0.18	0.41
		Full Divided Light Grilles	-	-	-
PassiveSun™ Enhanced w/HeatLock	Without Grilles	0.17	0.44	0.57	
	Simulated Divided Light Grilles	0.17	0.40	0.51	
	Finelight Grilles	0.18	0.40	0.51	
	Full Divided Light Grilles	-	-	-	

Andersen® Product	High-Performance Triple-Pane Glass Type	U-Factor ¹	SHGC ²	VT ³	
400 Series Elliptical Windows AND-N-16	Low-E4*	Without Grilles	0.24	0.31	0.53
		Simulated Divided Light Grilles	0.24	0.28	0.48
		Finelight™ Grilles	0.24	0.28	0.48
		Full Divided Light Grilles	-	-	-
	Low-E4 Enhanced	Without Grilles	0.20	0.31	0.51
		Simulated Divided Light Grilles	0.20	0.28	0.46
		Finelight Grilles	0.20	0.28	0.46
		Full Divided Light Grilles	-	-	-
	Low-E4 Enhanced w/HeatLock®	Without Grilles	0.18	0.29	0.50
		Simulated Divided Light Grilles	0.18	0.26	0.45
		Finelight Grilles	0.18	0.26	0.45
		Full Divided Light Grilles	-	-	-
	Low-E4 SmartSun™	Without Grilles	0.23	0.21	0.48
		Simulated Divided Light Grilles	0.23	0.19	0.43
		Finelight Grilles	0.24	0.19	0.43
		Full Divided Light Grilles	-	-	-
	Low-E4 SmartSun Enhanced	Without Grilles	0.19	0.21	0.46
		Simulated Divided Light Grilles	0.19	0.19	0.41
		Finelight Grilles	0.20	0.19	0.41
		Full Divided Light Grilles	-	-	-
	Low-E4 SmartSun Enhanced w/HeatLock	Without Grilles	0.17	0.20	0.45
		Simulated Divided Light Grilles	0.17	0.18	0.40
		Finelight Grilles	0.18	0.18	0.40
		Full Divided Light Grilles	-	-	-
PassiveSun™ Enhanced w/HeatLock	Without Grilles	0.18	0.43	0.55	
	Simulated Divided Light Grilles	0.18	0.39	0.50	
	Finelight Grilles	0.18	0.39	0.50	
	Full Divided Light Grilles	-	-	-	
400 Series Complementary Specialty Windows AND-N-105	Low-E4*	Without Grilles	0.22	0.34	0.58
		Simulated Divided Light Grilles	0.22	0.31	0.52
		Finelight™ Grilles	0.22	0.31	0.52
		Full Divided Light Grilles	-	-	-
	Low-E4 Enhanced	Without Grilles	-	-	-
		Simulated Divided Light Grilles	-	-	-
		Finelight Grilles	-	-	-
		Full Divided Light Grilles	-	-	-
	Low-E4 Enhanced w/HeatLock®	Without Grilles	0.15	0.32	0.55
		Simulated Divided Light Grilles	0.15	0.29	0.49
		Finelight Grilles	0.15	0.29	0.49
		Full Divided Light Grilles	-	-	-
	Low-E4 SmartSun™	Without Grilles	0.21	0.22	0.52
		Simulated Divided Light Grilles	0.21	0.20	0.47
		Finelight Grilles	0.21	0.20	0.47
		Full Divided Light Grilles	-	-	-
	Low-E4 SmartSun Enhanced	Without Grilles	-	-	-
		Simulated Divided Light Grilles	-	-	-
		Finelight Grilles	-	-	-
		Full Divided Light Grilles	-	-	-
	Low-E4 SmartSun Enhanced w/HeatLock	Without Grilles	0.15	0.21	0.49
		Simulated Divided Light Grilles	0.15	0.19	0.44
		Finelight Grilles	0.15	0.19	0.44
		Full Divided Light Grilles	-	-	-
PassiveSun™ Enhanced w/HeatLock	Without Grilles	0.15	0.47	0.60	
	Simulated Divided Light Grilles	0.15	0.43	0.54	
	Finelight Grilles	0.15	0.43	0.54	
	Full Divided Light Grilles	-	-	-	

Product Performance

*"Low-E4;" "Low-E4 SmartSun;" "Low-E4 PassiveSun" and "HeatLock" are Andersen trademarks for "Low-E" glass.

1) U-Factor defines the amount of heat loss through the total unit in BTU/hr-ft²-°F. The lower the value, the less heat is lost through the entire product. Window values represent non-tempered glass. Use of tempered glass can increase U-Factor ratings. See andersenwindows.com/nfrc for specific performance values. 2) Solar Heat Gain Coefficient (SHGC) defines the fraction of solar radiation admitted through the glass directly transmitted, as well as absorbed and subsequently released inward. The lower the value, the less heat is transmitted through the product. 3) Visible Transmittance (VT) measures how much light comes through a product (glass and frame). The higher the value, from 0 to 1, the more daylight the product lets in over the product's total unit area. Visible Light Transmittance is measured over the 380 to 760 nanometer portion of the solar spectrum.

*NFRC ratings are based on modeling by a third-party agency as validated by an independent test lab in compliance with NFRC program and procedural requirements.

*This data is accurate as of April 2025. Due to ongoing product changes, updated test results, or new industry standards or requirements, this data may change over time. Ratings are for sizes specified by NFRC for testing and certification. Ratings may vary depending on use of tempered glass, different grille options, glass with capillary breather tubes for high altitudes, etc.

*Values are for single units with given pane thickness and 3/4" (19 mm) grilles.

400 SERIES WINDOWS WITH TRIPLE-PANE GLASS



About the Label

Look for this certification label on every window and patio door you buy. The NFRC section was designed by the National Fenestration Rating Council to provide accurate information that helps you promote the energy efficiency of the homes you build. These ratings allow you – and your customers – to measure and compare the energy performance of similar products. If the product does not have this label, the NFRC has not verified its claims.

About the NFRC

The National Fenestration Rating Council (NFRC) is a nonpartisan coalition of professionals whose purpose is to provide fair, accurate and credible energy performance ratings for fenestration products. NFRC's membership includes manufacturers, suppliers, designers, specifiers, utility companies, government agencies and other building industry representatives.

Andersen Corporation is a founding member of the NFRC and continues to support its work by providing fair, accurate and credible energy performance ratings to consumers and the building industry. If you have any questions about the NFRC, its program or energy performance ratings, write them at: NFRC, 6305 Ivy Lane, Suite 410, Greenbelt, MD 20770. Phone: 301-589-1776. Website: nfrf.org

Product Performance

Do not remove until final code inspection. Save label for future reference.

ENERGY STAR® Certified in Highlighted Regions
Certifié ENERGY STAR dans les régions en surbrillance

Canada
energystar.gc.ca

ENERGY STAR

U.S. / É.U.
energystar.gov

ER/RE 25

DO NOT REMOVE UNTIL FINAL INSPECTION / NE PAS RETIRER AVANT L'INSPECTION FINALE

NFRC
National Fenestration Rating Council®
CERTIFIED

ANDERSEN
WINDOWS & DOORS

400 Series Casement Window
AND-N-1-04165-00001
Vinyl-Clad Wood Frame, Triple-Pane Low-E
SmartSun Enhanced Heatlock Glazing with Argon
Product Type: Casement

ENERGY PERFORMANCE RATINGS

U-Factor 0.20 (U.S./I-P)	Solar Heat Gain Coefficient 0.18
Visible Transmittance 0.42	

Manufacturer stipulates that these ratings conform to applicable NFRC procedures for determining whole product performance. NFRC ratings are determined for a fixed set of environmental conditions and a specific product size. NFRC does not recommend any product and does not warrant the suitability of any product for any specific use. Consult manufacturer's literature for other product performance information.
www.nfrc.org

WDMA
Hallmark Certified
www.wdma.com

Licensee: 129-H-861
Andersen Corporation
400 Series Casement Window
Manufacturer stipulates Hallmark Certification as indicated below.

STANDARD	RATING
AAMA/WDMA/CSA 1011.S.2/A440-11	Class LC-PG50 Size Tested 59.5" x 71.9" DP+50-50
AAMA/WDMA/CSA 1011.S.2/A440-08	Class LC-PG50 Size Tested 59.5" x 71.9" DP+50-50
AAMA/WDMA/CSA 1011.S.2/A440-08 A440S1-09	Class LC-PG50 Size Tested 1435 mm x 1826 mm Positive/Negative Design Pressure (DP) = 2400 Pa/-2400 Pa Water Penetration Resistance Test Pressure = 360 Pa Canadian Air Infiltration/Exfiltration = A3

FL 12496 Complies with HUD UM Bulletin No. 111.

Glazing: 3.0 mm AN outer / 3.0 mm AN middle / 3.0 mm AN inner

WARNING
This product can expose you to chemicals including titanium dioxide, which is known in the state of California to cause cancer, and methanol, which is known to the state of California to cause birth defects or other reproductive harm.
For more information go to www.P65Warnings.ca.gov

Meets or exceeds CEC & IECC Air Infiltration Requirements of 0.2 CFM/sq.ft. or lower.
WDMA Hallmark Certification Program.

Energy Rating (ER) represents "Energy Rating" and is a rating used in Canada for product comparison purposes (the higher the ER number, the more energy saved during the heating season).

ENERGY STAR® Climate Zone Map is based on U-Factor and solar heat gain coefficient criteria for specific ENERGY STAR climate zones within the United States and Canada. The shading of the map shows which climate zone(s) a particular product and glass type is ENERGY STAR Version 7.0 certified in. Visit andersenwindows.com/energystar for more details.

Solar Heat Gain Coefficient measures how well a product blocks heat caused by sunlight (the lower the number, the more it will help reduce the use of air conditioning and as a result, reduce electrical bills and energy use).

Performance Grade (PG) and Design Pressure (DP) Ratings

Glass Construction used with this product type.

U-Factor indicates how well a product prevents heat from escaping (the lower the number, the better).

Visible Transmittance refers to how much visible light comes through a product (the closer to 1.0, the more light is transmitted).

WDMA Hallmark Certification verifies the performance ratings of this product were tested by an independent testing laboratory and verified by a third-party certification program.

Test Standards

* NFRC ratings are based on modeling by a third-party agency as validated by an independent test lab in compliance with NFRC program and procedural requirements.
* "ENERGY STAR" is a registered trademark of the U.S. Environmental Protection Agency.



All trademarks where denoted are marks of their respective owners.
©2026 Andersen Corporation. All rights reserved. 04/26 Part #110041